

STRIKER AGM™

FLYING MODEL ROCKET ASSEMBLY INSTRUCTIONS

Things You'll Need To Assemble this Kit:

Pencil and Hobby Knife: 

White Glue:

Aliphatic Resin glue, such as TITEBOND or ELMER'S CARPENTER'S WOOD GLUE - ELMER'S WHITE SCHOOL GLUE also works but dries slower.



Medium CA Glue:

"CA" is the commonly used name for industrial grades of cyanoacrylate based fast-acting glues. Commonly sold under trade names like SUPERGLUE and CRAZY GLUE.



Plastic Cement:

Use TESTORS TUBE Plastic Cement, PACTRA LIQUID CEMENT or other comparable brands.



Tape:

Use Scotch Magic Tape or Paper Masking Tape.

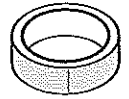

Finishing Supplies:

To finish your rocket so that it looks like the one pictured on the front of the package, you will need the following supplies: Sandpaper (220 or 320 Grit), Sanding Sealer or Balsa Filler and a small Paint Brush to apply it. Gloss Black, Gloss Gray and Gloss Red Spray Paint.

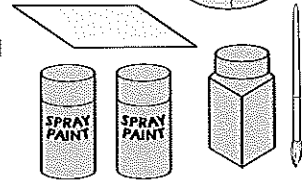

BEFORE STARTING ASSEMBLY READ THROUGH THESE INSTRUCTIONS. IT IS BEST TO TEST FIT ALL PARTS BEFORE APPLYING ANY GLUE. READ AND FOLLOW THE NAR MODEL ROCKET SAFETY CODE.



Prod. No. 2020
Skill Level Two

QUEST AEROSPACE, INC
PO Box 2409
Pagosa Springs, CO 81147
800-858-7302



PARTS LIST

- A. 11503 White Body Tube
- B. 14000 Blue Thrust Ring
- C. 49000 Motor Clip
- D. 10303S Yellow Motor Mount Tube
- E. 16001 Die-cut Center Ring
- F. 16002 Die-cut Center Ring
- G. 21056 Plastic Reducer
- H. 20201 Plastic Nose Cone Half Male
- I. 20202 Plastic Nose Cone Half Female
- J. 10001 Launch Lug
- K. 82302 Complete Parachute
- L. 50053 Kevlar* Shock Cord
- M. 50012 Elastic Shock Cord
- N. 2020-1030 Decal Sheet
- O. 33071 Balsa Fin Sheet
- P. 2020-1010 Instruction Sheet
- Q. 90960R2 Launch Procedure Sheet

* Kevlar is a registered trademark of Dupont

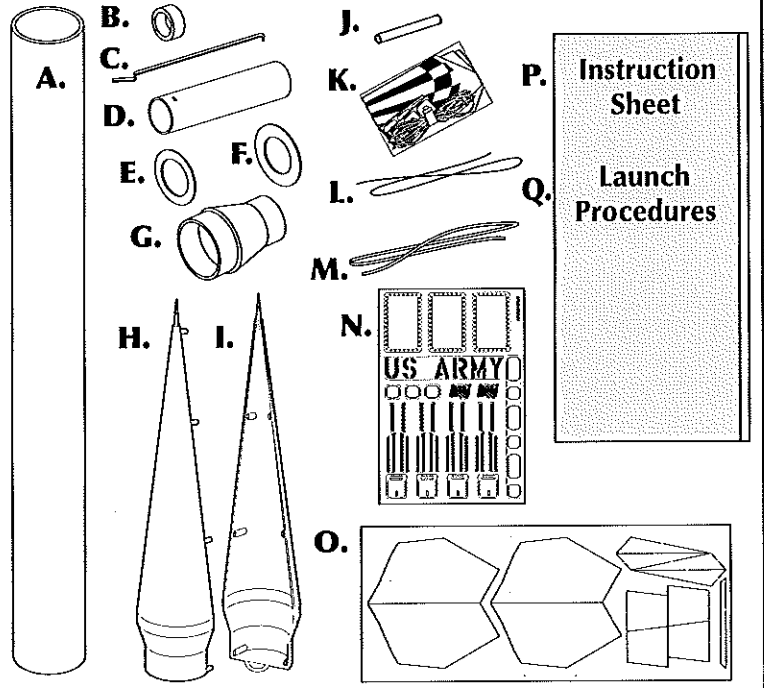

STEP 1

A. Insert the Motor Clip into the Slit of the Motor Mount Tube .

B. Tape the Motor Clip in place.

Insert End of Clip Into Slit in Tube

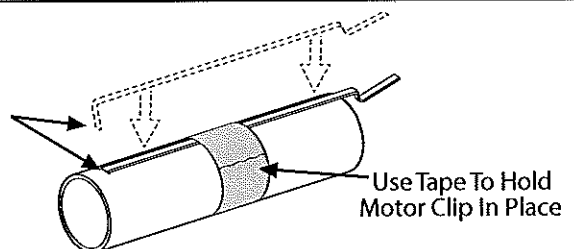

Use Tape To Hold Motor Clip In Place

STEP 2

- Use CA Glue to attach the Die-cut Centering Ring (16001) to one end of the Plastic Reducer.
- Use CA Glue to attach the Die-cut Centering Ring (16002) to one end of the Plastic Reducer.
- Make sure both Centering Rings are centered perfectly on Reducer ends.

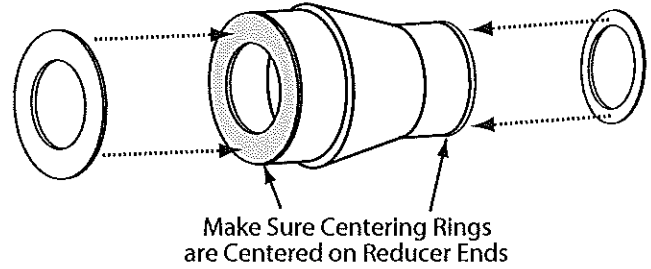

STEP 3

- Use no Glue and slide the Yellow Motor Tube into Assembly. Leave 1/4 inch of the Yellow Motor Tube extending out of the Aft End.
- Add Glue Fillets to both Ring/Motor Tube joints.

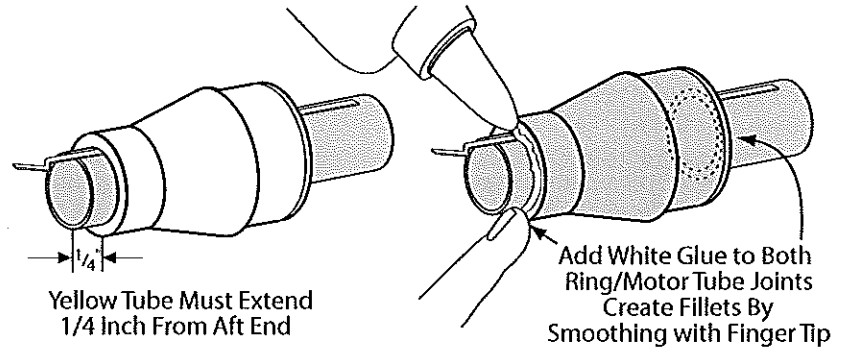

STEP 4

- Tie the Yellow Kevlar and White Elastic Shock Cords together.
- Tie the loose end of the Kevlar to the Blue Thrust Ring.
- Glue the Thrust Ring into the end of the Motor Mount Tube with White Glue.

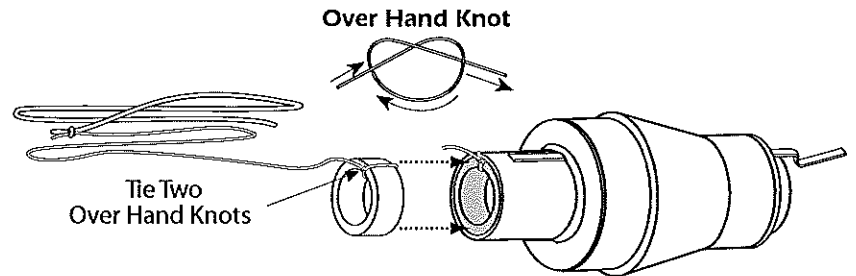

STEP 5

- Use CA Glue on the inside of the White Body Tube and insert the Motor Mount Assembly into the Tube.

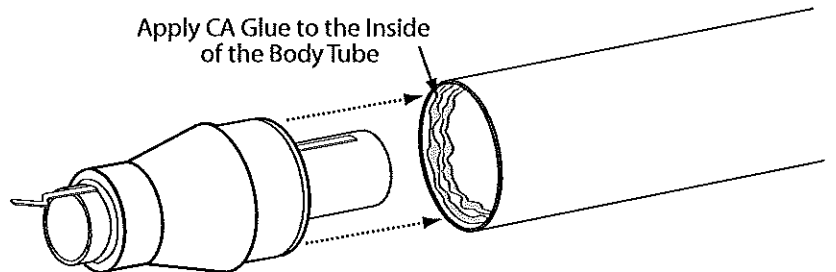

STEP 6

- There are four distinct molded lines in the Plastic Reducer. Use them as a guide to extend four Fin Lines down the Body Tube.
- Make an additional line for the Launch Lug down the Body Tube centered between two of the Fin Lines.
- Make a mark 3.5 inches from the end of Tube on the four Fin Lines.
- Make a mark 7 inches from the end of Tube on the line for the Launch Lug.

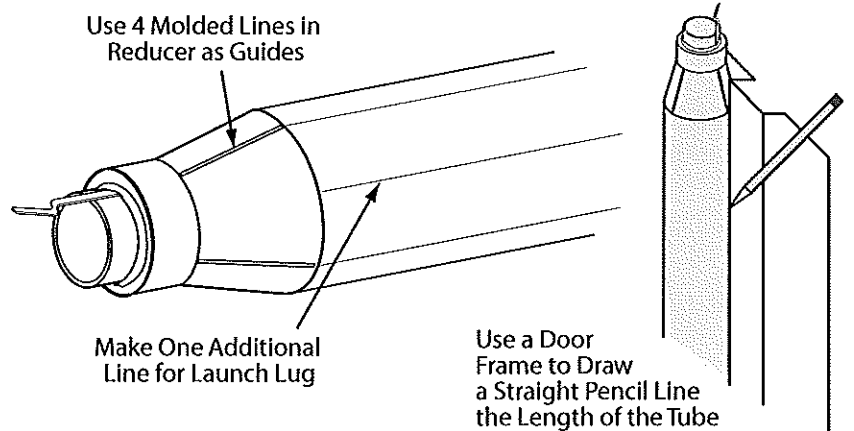

STEP 7

- A. Remove Balsa Fins from sheet.
- B. Stack and Sand alike parts. DO NOT DISTORT THE SHAPE OF THE REAR FIN. THE ROOT EDGE IS DESIGNED TO FIT AGAINST THE REDUCER PERFECTLY!
- C. Glue Strakes onto Leading Edge of each Rear Fin with White Glue. Use Wax Paper on a flat surface.

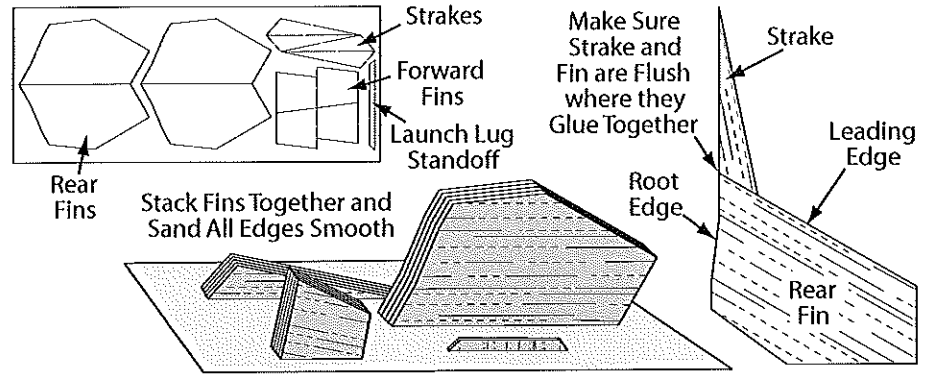

STEP 8

- A. After the Rear Fins Glued together in STEP 7 are dry, Glue them in place using CA Glue.
- B. Glue Forward Fins in place using White Glue.
- C. Create Fillets with White Glue everywhere the Balsa meets the White Body Tube on all 8 Fins.

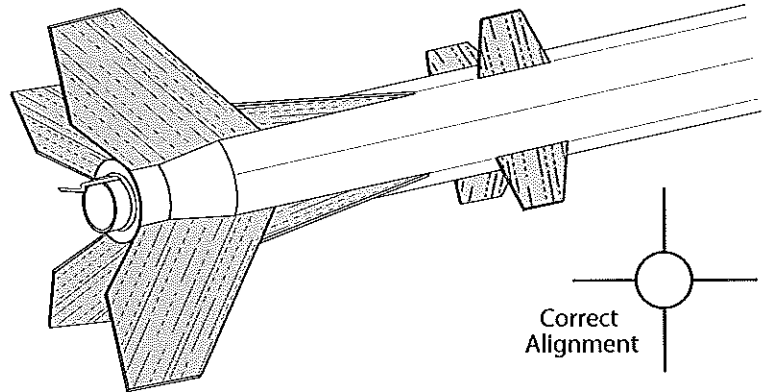

STEP 9

- A. Glue the Launch Lug Stand-Off to the line extended in STEP 6 at the 7 inch mark. Be sure the Launch Lug Stand-Off is aligned perpendicular to the Body Tube.
- B. Use White Glue to Glue the Launch Lug to the Launch Lug Stand-Off.
- C. Be sure the Launch Lug is aligned parallel to the Body Tube.

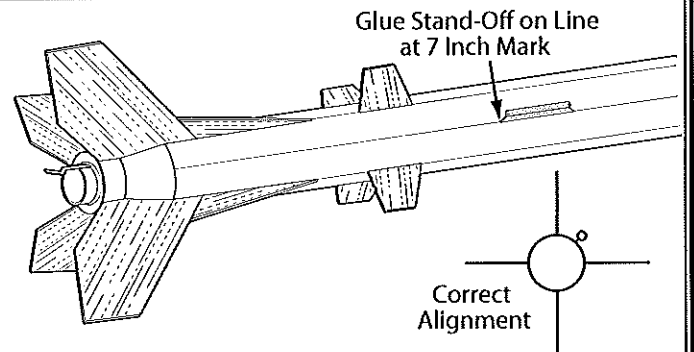

STEP 10

- A. Use a Hobby Knife to trim any Flash from Plastic Nose Cone Halves.
- B. Use Plastic Cement to Glue the Two Nose Cone Halves together.

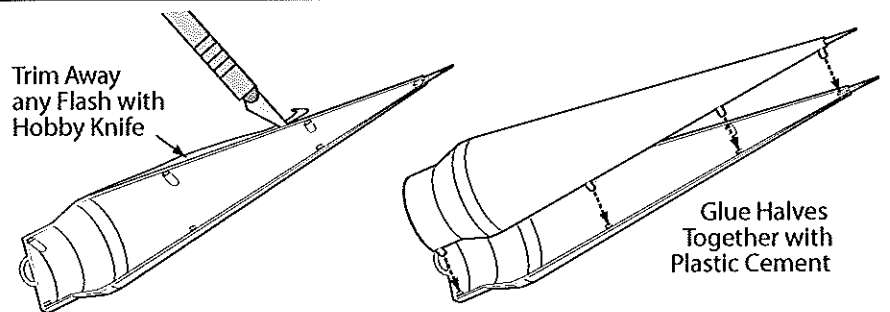

STEP 11

- A. Apply Sanding Sealer to all Balsa Fins and Launch Lug Stand Off. When Sealer is dry lightly Sand.
- B. Repeat the Sealing and Sanding process until the surface of each Fin is smooth.

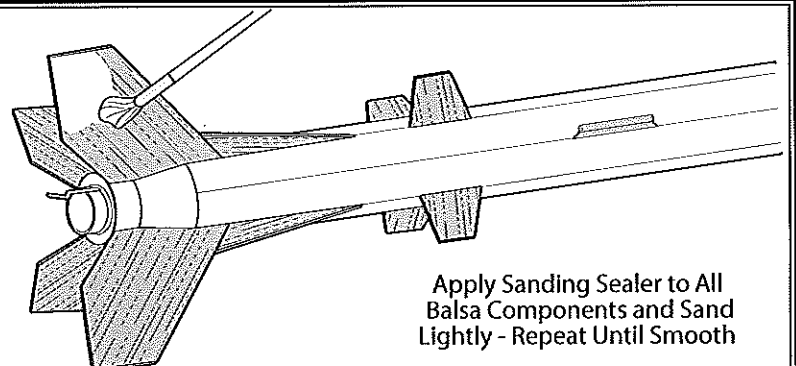

STEP 12

A. Paint the entire rocket body and fins with Gloss Gray Spray Paint. Follow instructions on the Spray Can for best results. Allow to dry completely.

B. After Gray Paint has dried completely, use Tape and masking material such as a paper or plastic grocery bag to cover the Gray components. Use Gloss Red and Gloss Black to complete your rocket as indicated. Use Photograph on packaging as a guide. Allow paint to dry completely between each color.

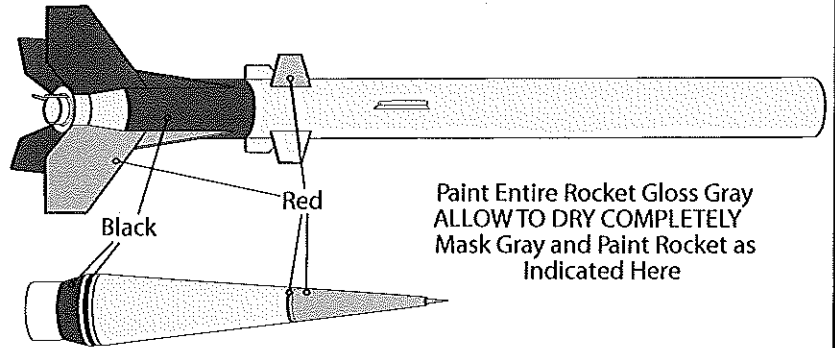

STEP 13

A. Use scissors to cut out the Decals.

B. Place Decals in lukewarm water. DO NOT PLACE MORE THAN ONE DECAL AT A TIME IN WATER! The Decals will curl as they get wet. When they start to uncurl (approx. 20-30 seconds) remove from water and slip from backing into position on rocket. Blot dry with tissue or paper towel.

C. Use this photo as a guide to apply each Decal.

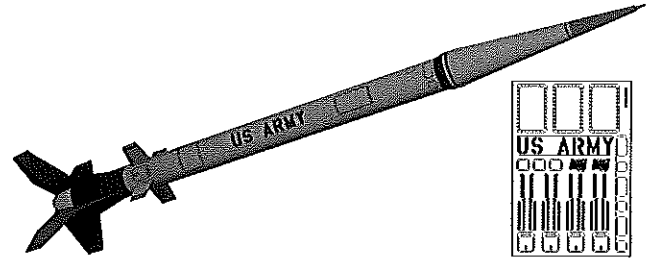

STEP 14

A. Apply Gripper Tabs to Parachute so holes in Gripper Tabs line up with holes in Parachute. Firmly squeeze each Gripper and Parachute between your fingers.

B. Assemble the Parachute by passing the end of a Shroud Line through a hole in a Gripper Tab and tying 2 Over Hand Knots. Tie each of the ends of the Shroud Line to the Parachute through the Gripper Tab holes.

C. Assembled Parachute should appear as shown.

Squeeze Gripper Between Fingers

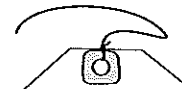
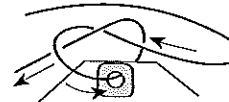

Tie 2 Over Hand Knots Through Each Gripper

STEP 15

A. Pass the shroud line loops through the eyelet on the nose cone.

B. Pass parachute through loop ends and pull lines tightly against the eyelet.

C. Use two overhand knots to tie the loose end of the shock cord onto the base of the nose cone.

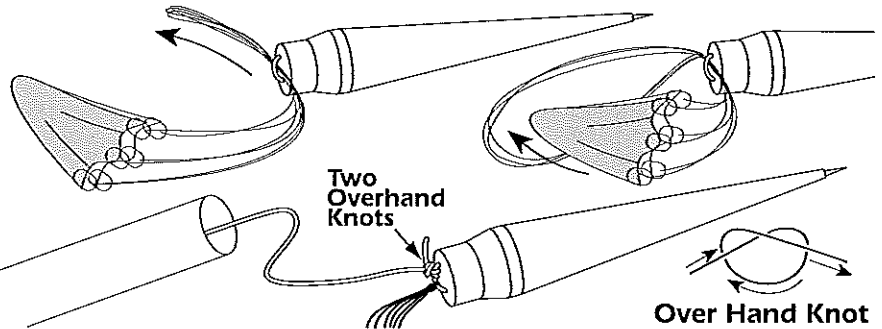

FLYING YOUR STRIKER AGM ROCKET

WHAT ELSE YOU WILL NEED

To successfully fly your rocket you will need the following items:

- QUEST Lift Off Launch Pad (No. 7610)
- QUEST Futuristic Launch Controller (No. 7510)
- QUEST Parachute Recovery Wadding (no. 7021)
- QUEST Rocket Motors, Type B6-4, C6-3 or C6-5
- Use a B6-4 Motor for your first flight

PREPPING YOUR ROCKET FOR FLIGHT

STEP 1 Pull the shock cord all the way out of the body tube. Crumple four sheets of recovery wadding and insert one by one into the body tube making sure that the knot between the Kevlar and white elastic shock cord is on the nose cone side of the wadding. Wadding should fit loosely in the tube but tight enough to form a good seal against the wall of the body tube.

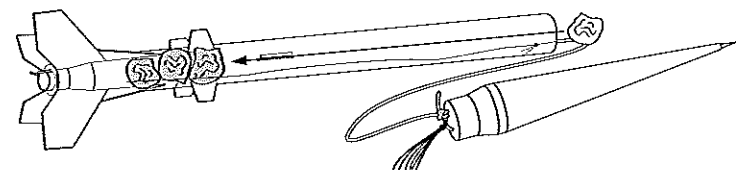

STEP 2

- Grab the parachute at its center and allow the rocket to hang from it. The weight of the rocket will pull the parachute into several triangular shapes.
- Gather the triangles together into one flat triangle.
- Fold the top of the parachute down over itself once.
- Now continue to roll the parachute over itself and roll the shroud lines around it.

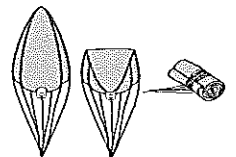

STEP 3

- Pack the parachute into the body tube. The parachute must fit loosely into the tube. If it is a tight fit, remove and re-fold the parachute.
- TIP:** Lightly dust your parachute with talcum powder or baby powder to keep it from developing a set shape. This technique is especially effective if the weather is hot and humid or very cold.
- Push the shock cord into the tube and re-fit the nose cone onto the rocket. Be careful not to catch any of the shock cord between the shoulder of the nose cone and the body tube

READ AND FOLLOW THE ENCLOSED LAUNCH PROCEDURE SHEET AND THE N.A.R. SAFETY CODE DURING ALL MODEL ROCKETRY ACTIVITIES.