

# GAMMA-RAY™

## FLYING MODEL ROCKET ASSEMBLY INSTRUCTIONS



Prod. No. 2004  
Skill Level Two

QUEST AEROSPACE, INC  
PO Box 2409  
Pagosa Springs, CO 81147  
© 2010 All rights Reserved  
800-858-7302

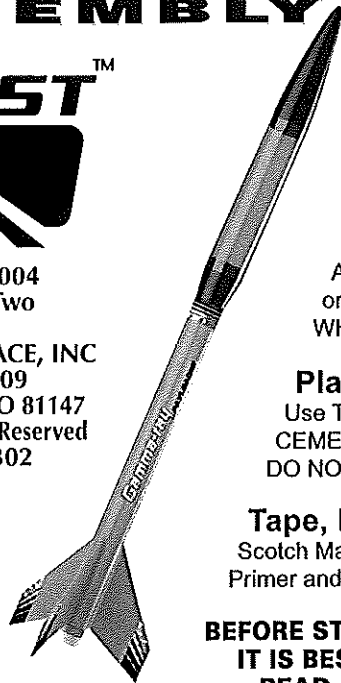

**Things You'll Need To Assemble this Kit:**  
Pencil, Hobby Knife and Paint Brush:

**Sandpaper** (220 or 320 Grit) & Sanding Sealer

### White Glue

Aliphatic Resin glues work best such as TITEBOND or ELMER'S CARPENTER'S WOOD GLUE - ELMER'S WHITE SCHOOL GLUE also works but dries slower.

### Plastic Cement

Use TESTORS TUBE Plastic Cement, PACTRA LIQUID CEMENT or other comparable brands. DO NOT use cyanoacrylate glue.

### Tape, Primer & Paint

Scotch Magic Tape or Paper Masking Tape, Spray Primer and Spray Paint.

**BEFORE STARTING ASSEMBLY READ THROUGH THESE INSTRUCTIONS. IT IS BEST TO TEST FIT ALL PARTS BEFORE APPLYING ANY GLUE. READ AND FOLLOW THE NAR MODEL ROCKET SAFETY CODE.**

## PARTS LIST

- A. 10001 2" Launch Lug
  - B. 10303S Yellow Motor Mount Tube
  - C. 11201 8.5" White Body Tube
  - D. 14000 Blue Motor Thrust Ring
  - E. 20171 Plastic Nose Cone
  - F. 21054 Small Plastic Transition
  - G. 50101 Gripper Tabs
  - H. 28107 14" Plastic Parachute
  - I. 28200 4" Red Payload Tube
  - J. 33000 Laser-Cut Balsa Wood Fins
  - K. 33011 Launch Lug Stand-Off
  - L. 49000 Motor Mount Clip
  - M. 50014 18" White Elastic Shock Cord
  - N. 50051 12" Yellow Kevlar Shock Cord
  - O. 50100 3/26" Shroud Lines
  - P. 90063 Gamma-Ray Instruction Sheet
  - Q. 90163 Gamma-Ray Flight/L.P. Sheet
  - R. 91013 Gamma-Ray Decal Sheet
- \* Kevlar is a registered trademark of Dupont

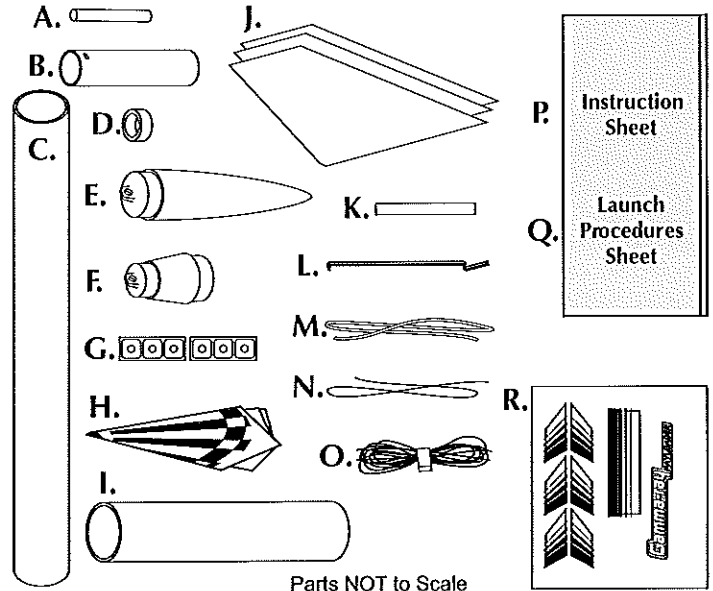

OVERLAP AREA

TUBE MARKING GUIDE

## STEP 1

**A.** Hold the Yellow Kevlar Shock Cord and the White Elastic Shock Cord side by side. Pull one end of each cord so that they are even with each other. While holding the two cords together, tie a single parallel overhand knot approximately one inch from the even ends as shown.

**B.** Gently pull on both cords to set the knot and prevent it from slipping.

**C.** Apply a small amount of white glue on the ends of both cords to prevent them from fraying.

**NOTE: THIS IS A VERY IMPORTANT STEP. IF YOU TIE A DIFFERENT TYPE OF KNOT THE SHOCK CORDS MAY SEPARATE DURING FLIGHT.**

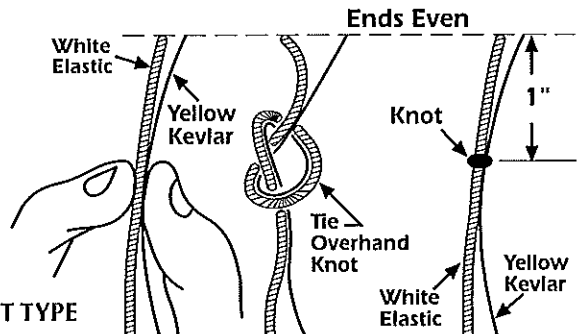

## STEP 2

A. Use a sharp hobby knife to cut a shallow "V" slot in the Blue Thrust Ring as shown. Test fit the Blue Thrust Ring into one end of the Yellow Motor Mount Tube. If the fit is tight, sand the outside of the Blue Thrust Ring until you get a looser fit.

B. Tie the Yellow Kevlar Shock Cord onto the Blue Thrust Ring using two overhand knots as shown. Be sure the shock cord lays in the "V" you made in the Blue Thrust Ring.

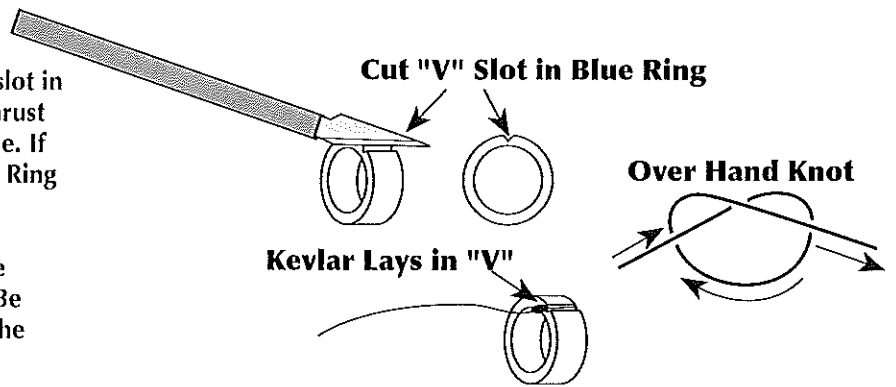

## STEP 3

A. Apply white glue around the inside edge of the Yellow Motor Mount Tube in the end with a slit in it, as shown.

B. Insert the Blue Thrust Ring into the Yellow Motor Mount Tube with the Yellow Kevlar and knot facing as shown until it is even with the end of the Yellow Motor Mount Tube.

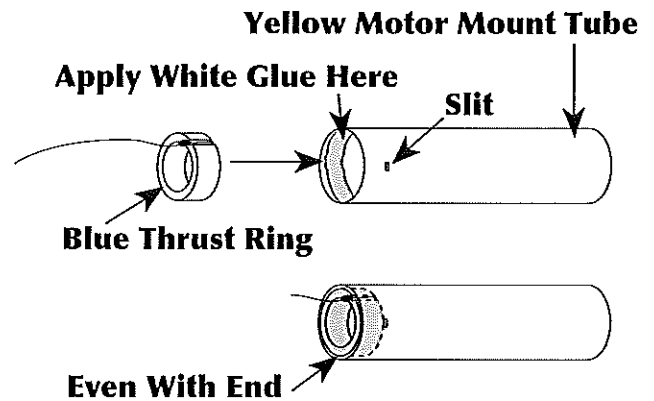

## STEP 4

A. Using the ruler on the front of the instruction sheet, make a pencil mark 1/4 inch from the end of the Yellow Motor Mount Tube as shown.

B. "Feed" the shock cord back through the Yellow Motor Mount as shown.

C. Make a slight bend in the motor clip as shown. Insert the clip into the slit in the Yellow Motor Mount Tube.

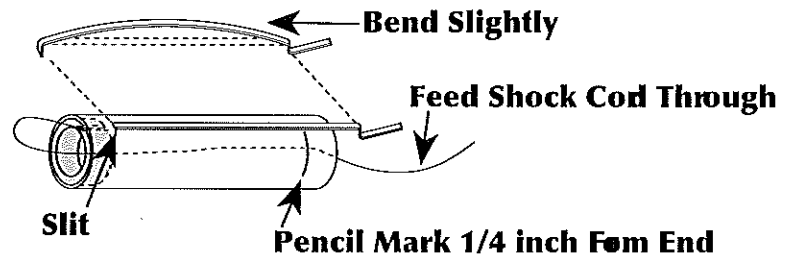

## STEP 5

A. Apply white glue around the inside of one end of the White Body Tube.

B. Orient the Yellow Motor Mount tube as shown and immediately insert it into the White Body Tube and PUSH INTO THE BODY TUBE WITH ONE FAST & SMOOTH MOTION up to the 1/4 inch pencil mark on the Yellow Motor Mount Tube as shown.

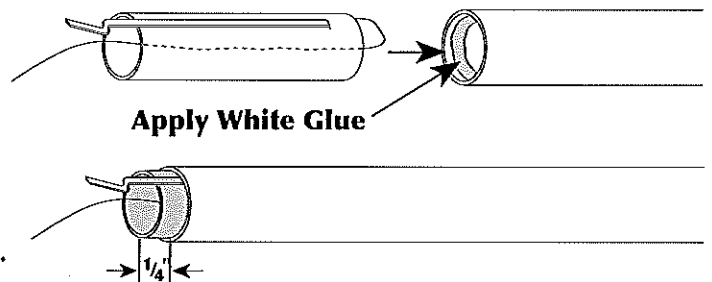

## STEP 6

A. Cut out the tube marking guide from the front page of the instruction sheet

B. Wrap the tube marking guide around the body tube. Align the arrow that is marked "Launch Lug" with the motor clip. Mark the body tube at each of the arrows with a pencil.

C. Use a door frame as a guide and extend each of the pencil marks 3 inches up from the rear of the body tube.

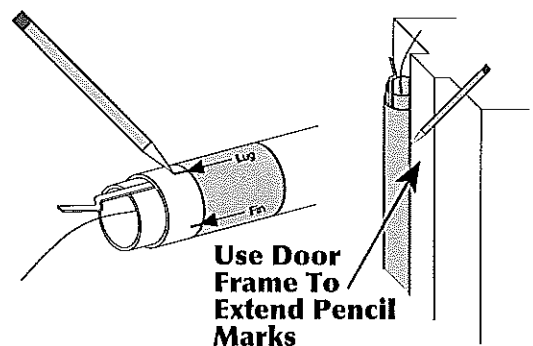

## STEP 7

- A. Carefully remove each of the three laser-cut balsa fins from the sheet with a sharp hobby knife.
- B. Stack the fins together and sand all edges smooth.
- C. Rub a small line of white glue into the root edge of each fin and set aside to dry.

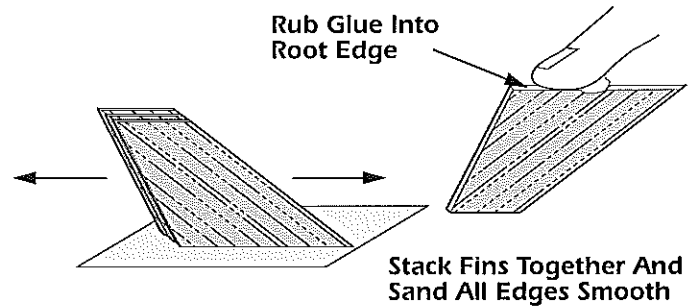

## STEP 8

- A. Apply a small line of white glue along the root edge of a fin and position it along one of the fin lines on the body tube. Adjust the fin so that it projects straight away from the body tube as shown. Allow the glue to set for a few minutes before attempting to glue on the remaining fins. Repeat this step for the remaining two fins.
- B. After the glue is completely dry apply a small bead of white glue to both sides of a fin-body tube joint. Smooth out the glue with your finger. Wipe excess glue off your finger onto a tissue or paper towel.
- C. Repeat the above step for the remaining fin-body tube joints. Set aside to dry.

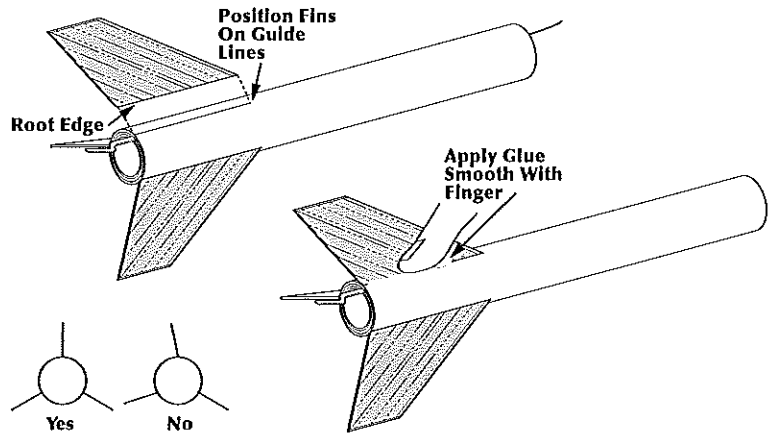

## STEP 9

- A. Make a pencil mark on the launch lug line 3.5 inches from the rear of the rocket as shown.
- B. Apply white glue to the launch lug stand-off and place along the pencil line with one end even with the mark 3.5 inches from the rear of the rocket as shown.
- C. Apply white glue to the launch lug and place it along the outer edge of the stand-off as shown.

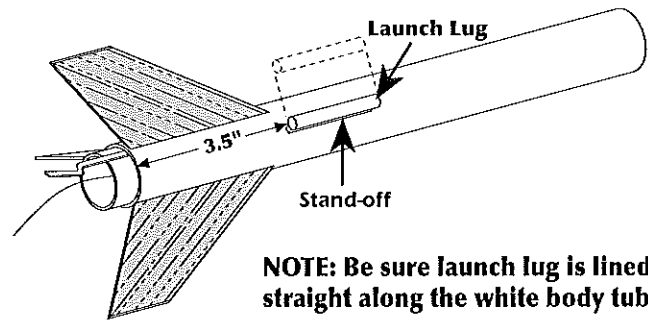

**NOTE:** Be sure launch lug is lined up straight along the white body tube

## STEP 10

- A. After all the glue is completely dry apply a coat of sanding sealer to each fin. When sealer is dry, lightly sand each fin.
- B. Repeat the sealing and sanding process until the surface of each fin is smooth.
- C. Paint the entire rocket body and fins with spray primer. Follow instructions on the spray can for best results. Allow to dry and sand smooth.
- D. Paint the entire rocket body and fins with gloss red spray enamel. Follow instructions on the spray can for best results.

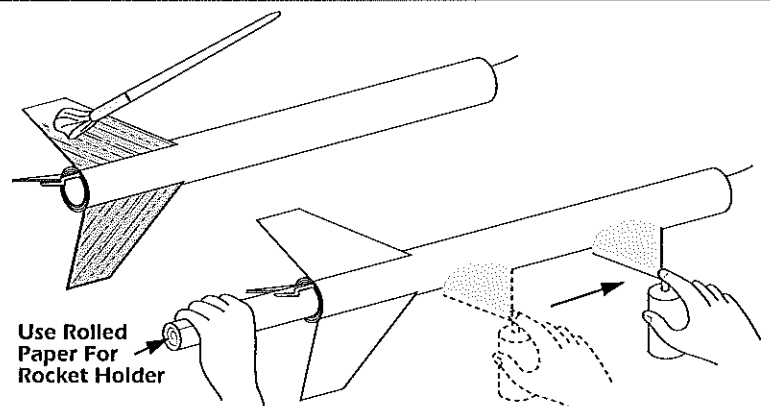

## STEP 11

- A. If you don't intend to use the Gamma-Ray to carry payloads, we recommend you glue the Nose Cone and Transition to the Payload Tube.
  - B. If you don't glue these parts, make certain their fit is tight. This can be done by wrapping a piece of masking tape around the shoulder of the nose cone and the payload transition.
- NOTE:** Failure to glue or create a tight fit between these pieces may result in loss of nose cone, payload tube and payload.

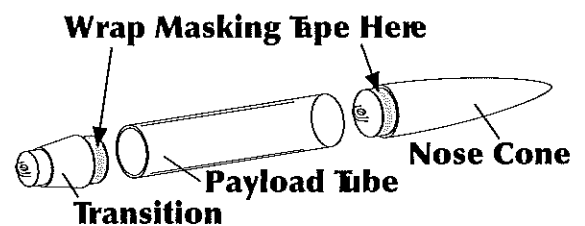

## STEP 12

A. Apply gripper tabs to parachute so holes in gripper tabs line up with holes in parachute. Firmly squeeze each gripper tab and parachute between your fingers.

B. Assemble the parachute by passing the end of a shroud line through a hole in a gripper tab and tying 2 overhand knots. Tie each of the 6 ends of shroud line to the parachute through the gripper tab holes.

C. Assembled parachute should appear as shown.

Squeeze Gripper  
Between Fingers

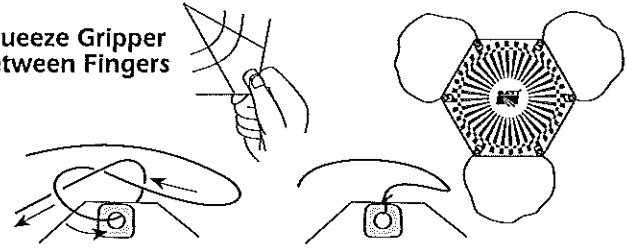

Tie 2 Over Hand Knots Through Each Gripper

## STEP 13

A. Pass the shroud line loops through the eyelet on the transition base. Pass parachute through loop ends and pull lines tightly against the eyelet.

B. Use two overhand knots to tie the loose end of the shock cord onto the base of the transition.

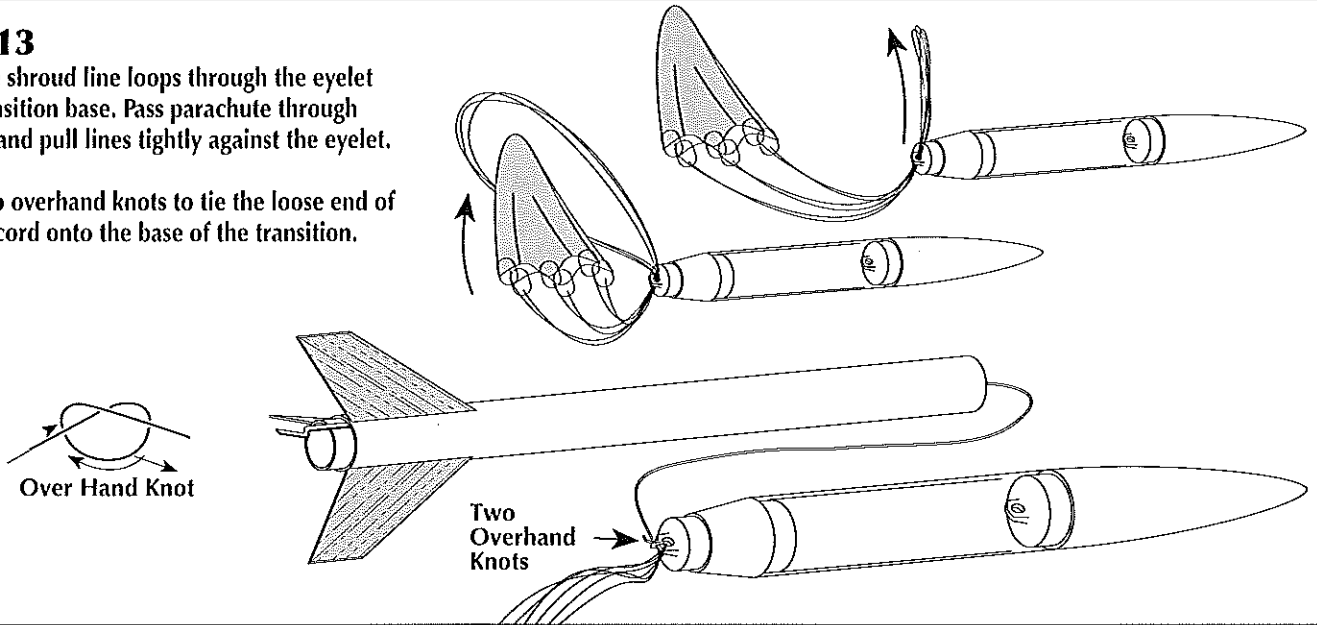

Over Hand Knot

Two  
Overhand  
Knots

## STEP 14

A. Apply the self-adhesive decals to your rocket as shown here.

**NOTE:** Use caution when removing the decal from the backing to prevent decal from curling over onto itself.

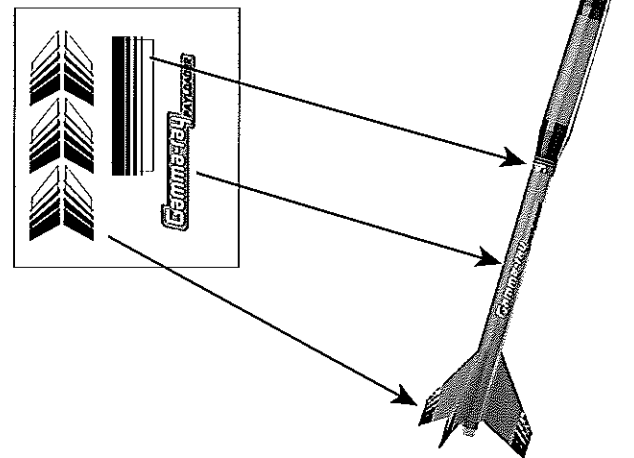

**READ AND FOLLOW THE ENCLOSED  
LAUNCHING PROCEDURE SHEET**

# FLYING YOUR GAMMA-RAY ROCKET

## WHAT ELSE YOU WILL NEED

To successfully fly your rocket you will need the following items:

- QUEST Lift Off Launch Pad (No. 7610)
- QUEST Futuristic Launch Controller (No. 7510)
- QUEST Parachute Recovery Wadding (no. 7021)
- QUEST Rocket Motors, Type A6-4, B6-4 or C6-5
- Use a A6-4 Motor for your first flight.

## ESTIMATED ALTITUDES

The following is a guide to assist you in determining which motor to use based on the wind conditions and size of flying field available.

MOTOR	ESTIMATED ALTITUDE
A6-4	250 FEET
B6-4	450 FEET
C6-5	900 FEET

## PREPPING YOUR ROCKET FOR FLIGHT

### STEP 1

Pull the shock cord all the way out of the body tube. Crumple two sheets of recovery wadding and insert one by one into the body tube making sure that the Knot between the Kevlar and white elastic shock cord is on the nose cone side of the wadding. Wadding should fit loosely in the tube but tight enough to form a good seal against the wall of the body tube.

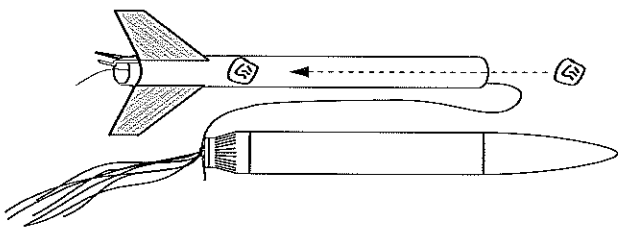

### STEP 2

- Grab the parachute at its center and allow the rocket to hang from it. The weight of the rocket will pull the parachute into several triangular shapes.
- Gather the triangles together into one flat triangle.
- Fold the top of the parachute down over itself once.
- Now continue to roll the parachute over itself and roll the shroud lines around it.

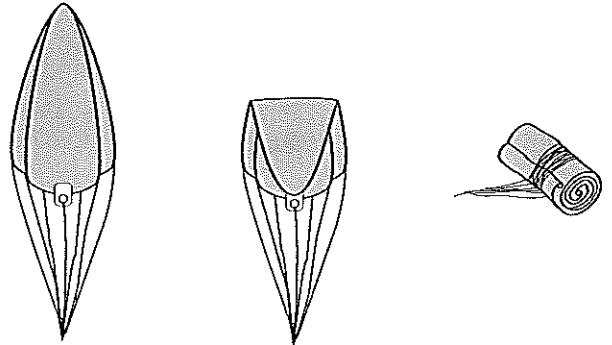

### STEP 3

- Pack the parachute into the body tube. **THE PARACHUTE MUST FIT LOOSELY INTO THE TUBE.** If it is a tight fit, remove and re-fold the parachute.

**TIP:** Lightly dust your parachute with talcum powder or baby powder to keep it from developing a set shape. This technique is especially effective if the weather is hot and humid or very cold.

- Push the shock cord into the tube and re-fit the nose cone onto the rocket. **BE CAREFUL NOT TO CATCH ANY OF THE SHOCK CORD BETWEEN THE SHOULDER OF THE NOSE CONE AND THE BODY TUBE**

**READ AND FOLLOW THE ENCLOSED LAUNCH PROCEDURE SHEET**

**READ AND FOLLOW THE N. A. R. SAFETY CODE DURING ALL YOUR MODEL ROCKETRY ACTIVITIES.**

## Take A Quest Rocketry Adventure!

- Launch An Interplanetary Starship
- Blast-Off A Real Two-Stage Rocket
- Fly A Military Style Missile Design
- Glide A Shuttle Craft Back To Earth

Visit our website at:

**questaerospace.com**

**QUEST**  
Shaping the future of model rocketry

QUEST AEROSPACE, INC.  
PO Box 2409  
Pagosa Springs, CO 81147  
800-858-7302

