

Payloader One ASSEMBLY INSTRUCTIONS

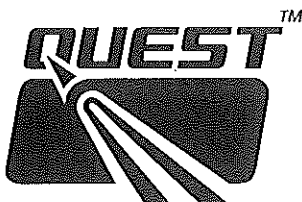

Product No. 1018

Skill Level One

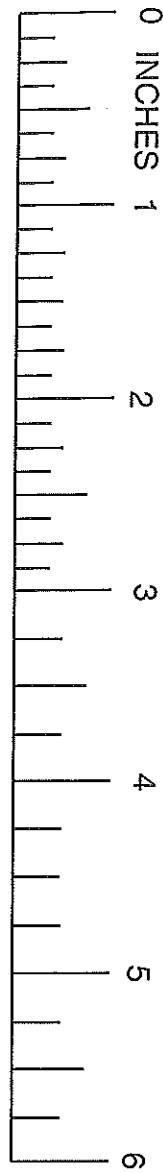
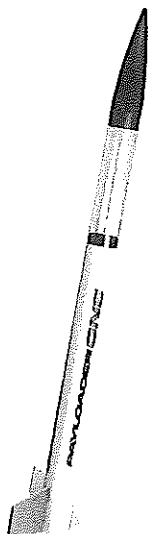

Things You'll Need To Assemble this Kit:

Hobby Knife, Pencil and Paint Brush



Sandpaper (220 or 320 Grit) & Sanding Sealer

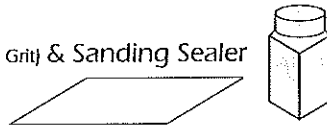

White Glue

Aliphatic Resin glues work best such as TITEBOND or ELMER'S CARPENTER'S WOOD GLUE - ELMER'S WHITE SCHOOL GLUE also works but dries slower.



Tape & Paint

Scotch Magic Tape or Paper Masking Tape, Spray Primer and Spray Paint.

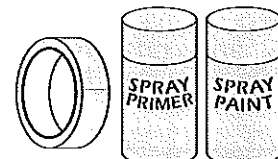

BEFORE STARTING ASSEMBLY READ THROUGH THESE INSTRUCTIONS. IT IS BEST TO TEST FIT ALL PARTS BEFORE APPLYING ANY GLUE. READ AND FOLLOW THE NAR MODEL ROCKET SAFETY CODE.

PARTS LIST

- A. 11312 White Body Tube With Fin Slots
- B. 49000 Motor Clip
- C. 14000 Blue Thrust Ring
- D. 10303S Yellow Motor Mount Tube
- E. 14050 Red Centering Ring (2)
- F. 20171 Plastic Nose Cone
- G. 28700 Clear Plastic Payload Tube
- H. Q-PC-25B Tube Coupler
- I. 10000 Launch Lug
- J. 50014 21 inch White Elastic Shock Cord
- K. 50051 18 inch Yellow Kevlar* Shock Cord
- L. 50100 3 - 26" Shroud Lines
- M. 50101 2 strips of 3 Tyvek Gripper Tabs
- N. 28107 14 inch Parachute
- O. 01018-1030 Self-Adhesive Decal
- P. 33050 Die-Cut Balsa Fin Set
- Q. 01018-1010 Instruction Sheet
- R. 01018-1011 Launch Procedures Sheet

* Kevlar is a registered trademark of Dupont

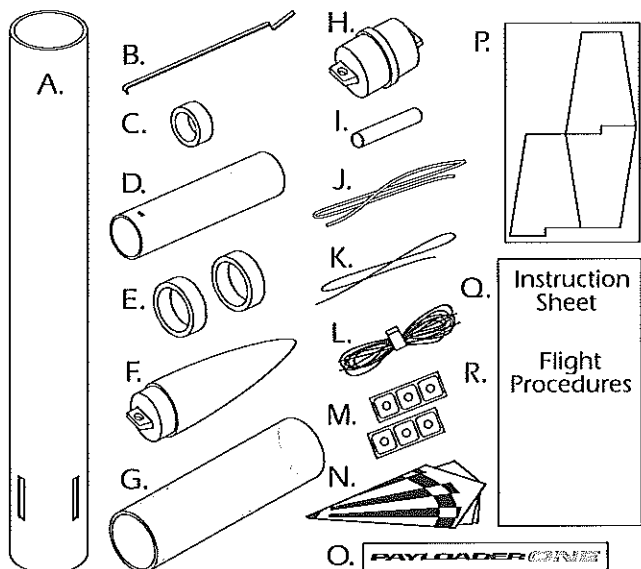

Parts not to scale.

STEP 1

A. Place the Yellow Motor Mount Tube up against the ruler provided above. Make two pencil marks on the tube 1/2 inch from each end as shown.

B. Make a slight bend in the Motor Clip as shown. Insert the Motor Clip into the slit in the Yellow Motor Mount Tube.

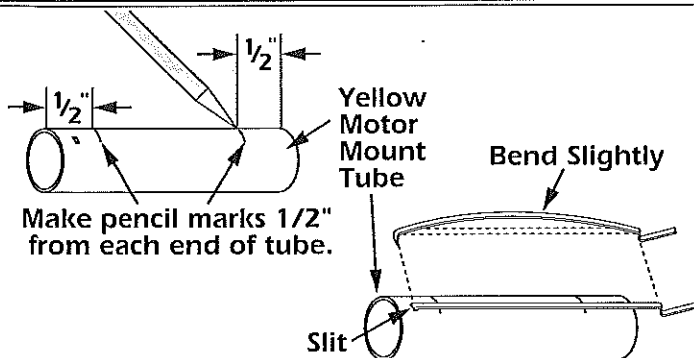

STEP 2

A. Test fit one of the Red Centering Rings onto the Yellow Motor Mount Tube. If it does not slide on easily, stretch the Red Ring by sliding it over the Nose Cone and gently twisting it back and forth a few times. Slide the Red Ring onto the Yellow Tube just far enough to hold the Motor Clip in place.

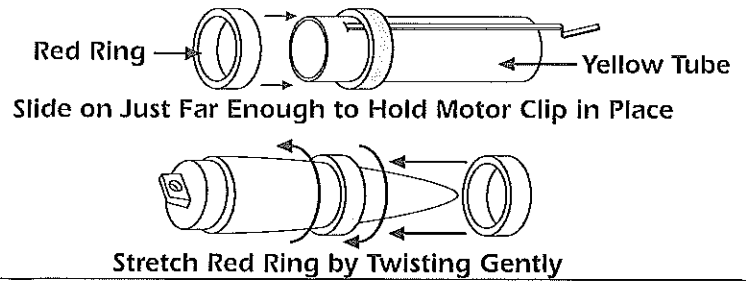

STEP 3

A. Apply a bead of white glue around the Yellow Motor Mount Tube on the inside of the pencil mark made in Step 1, one half inch from the end as shown.

B. Slide the Red Ring into the bead of glue and up to the pencil mark. The edge of the Red Ring must be 1/2" from end of the Yellow Motor Mount Tube. Wipe away any excess glue.

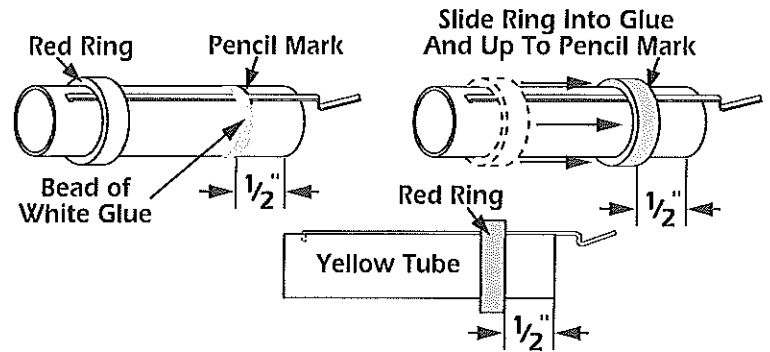

STEP 4

A. Tie two overhand knots 1 inch in from the end of the Kevlar Cord.

B. Pass the end of the Kevlar with the knot through the remaining Red Centering Ring.

C. Slide the Red Centering Ring with the Kevlar under it onto the Yellow Motor Mount Tube.

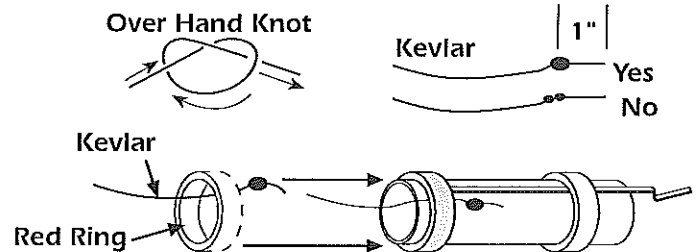

STEP 5

A. Apply a bead of white glue around the Yellow Motor Mount Tube on the inside of the pencil mark made in Step 1, one half inch from the end as shown.

B. Slide the Red Ring into the bead of glue until the pencil mark is exposed. If the Red Ring is tight, stretch it as in step 2 above. The edge of the Red Ring must be 1/2" from end of the Yellow Motor Mount Tube. Wipe away any excess glue.

C. Pull the Yellow Kevlar Shock Cord up tight against the Red Centering Ring.

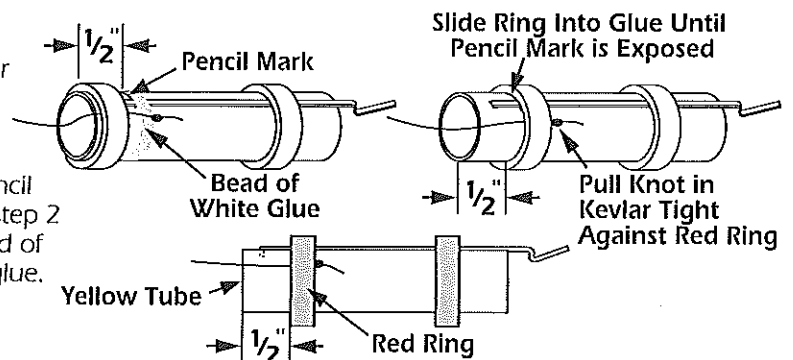

STEP 6

A. Apply white glue around inside edge of Yellow Motor Mount Tube as shown,

B. Insert the Blue Thrust Ring into the Yellow Motor Mount Tube so it is even with the end of the Yellow Motor Mount Tube.

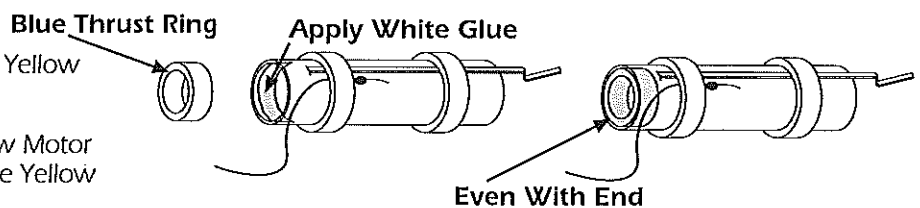

STEP 7

A. Hold the Yellow Kevlar Shock Cord and the White Elastic Shock Cord side by side. Pull one end of each cord so that they are even with each other. While holding the two cords together, tie a single parallel overhand knot approximately one inch in from the even ends as shown.

B. Gently pull on both cords to set the knot and prevent it from slipping.

C. Apply a small amount of white glue on the ends of both cords to prevent them from fraying.

NOTE: THIS IS A VERY IMPORTANT STEP. IF YOU TIE A DIFFERENT TYPE OF KNOT THE SHOCK CORDS MAY SEPARATE DURING FLIGHT.

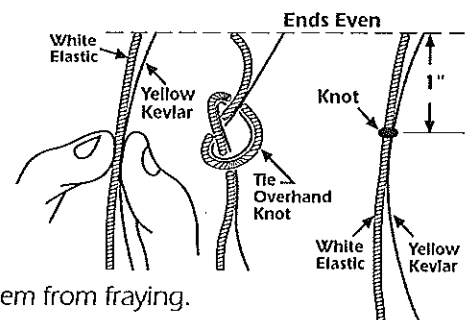

STEP 8

- Stretch the end of the Body Tube that has the Fin Slits in it slightly by inserting the nose cone into the tube and gently twisting it back and forth a few times.
- Hold the Body Tube with the stretched end facing up and "feed" the shock cord into the tube until the cord comes out the other end.
- Grab the end of the shock cord and pull it all the way through the tube until the Motor Mount assembly that is attached to the other end pulls up against the tube.

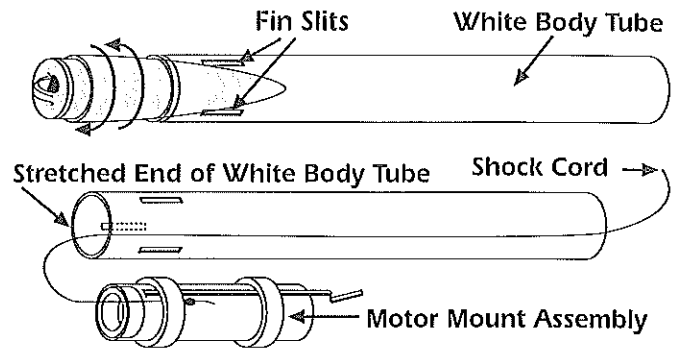

STEP 9

- Hold the Motor Mount Assembly and the Body Tube in one hand.
- Apply White Glue around the inside of the Body Tube just beyond the Fin Slits.
- Align the Motor Mount Assembly so the Motor Clip is centered between two of the Fin Slits.
- Immediately insert the Motor Mount Assembly and PUSH IT INTO THE BODY TUBE WITH ONE FAST & SMOOTH MOTION until the Yellow Motor Mount Tube is even with the end of the Body Tube.

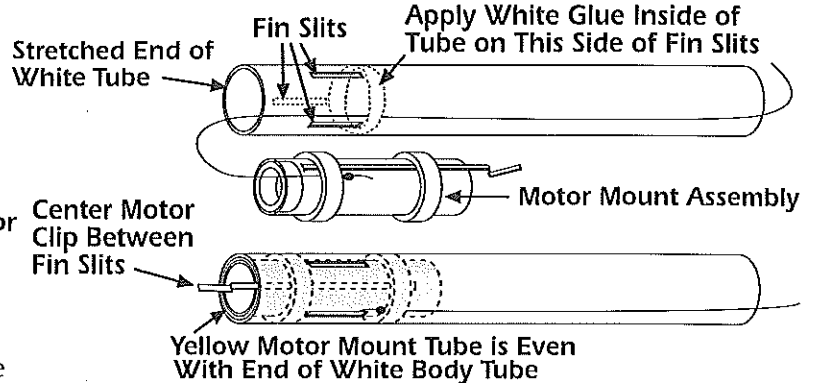

STEP 10

- Carefully remove each of the three die-cut balsa fins from the sheet with a sharp hobby knife.
- Stack the fins together and sand all edges smooth.
- Rub a small line of white glue into the root edge of each fin and set aside to dry.

Stack Fins Together And Sand All Edges Smooth

Rub Glue Into Root Edge

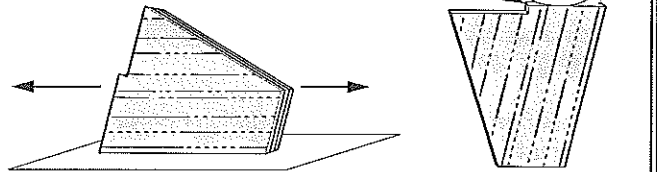

STEP 11

- Apply a small line of white glue along the root edge of a fin and insert it into one of the fin slots on the body tube. Adjust the fin so that it projects straight away from the body tube as shown. Allow the glue to set for a few minutes before attempting to glue on the remaining fins. Repeat this step for the remaining two fins.
- After the glue is completely dry apply a small bead of white glue to both sides of a fin-body tube joint. Smooth out the glue with your finger. Wipe excess glue off your finger onto a tissue or paper towel.
- Repeat the above step for the remaining fin-body tube joints. Set aside to dry.

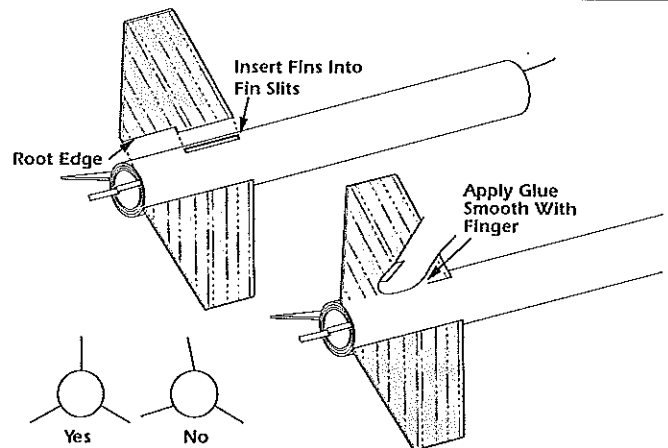

STEP 12

- Make a pencil mark 4 inches from the rear of the rocket aligned with the Motor Clip as shown.
- Apply white glue to the launch lug and place with one end even with the mark 4 inches from the rear of the rocket as shown.

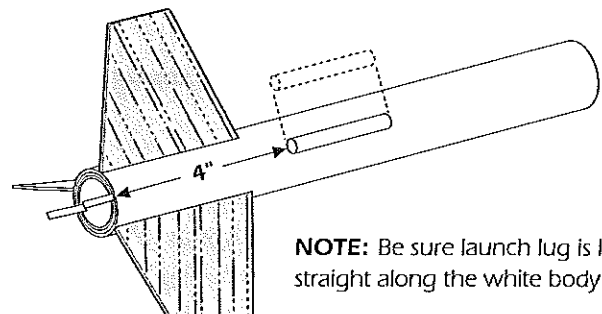

NOTE: Be sure launch lug is lined up straight along the white body tube.

STEP 13

- A. After all the glue is completely dry apply a coat of sanding sealer to each fin. When sealer is dry, lightly sand each fin.
- B. Repeat the sealing and sanding process until the surface of each fin is smooth.
- C. Paint the entire rocket body and fins with spray primer. Follow instructions on the spray can for best results. Allow to dry and sand smooth.

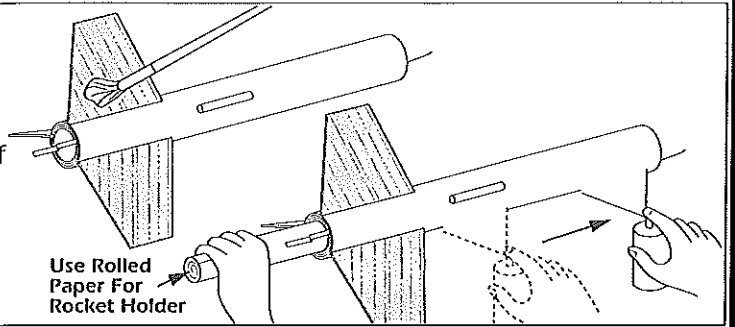

STEP 14

- A. Paint the entire rocket body and fins with gloss white spray enamel. Allow to dry completely.
- B. Apply masking tape around both sides of one body tube-fin joint. Protect the rest of the rocket with a plastic or paper bag. Spray paint one fin with several light coats of gloss orange paint. Carefully remove the masking tape after paint is dry.

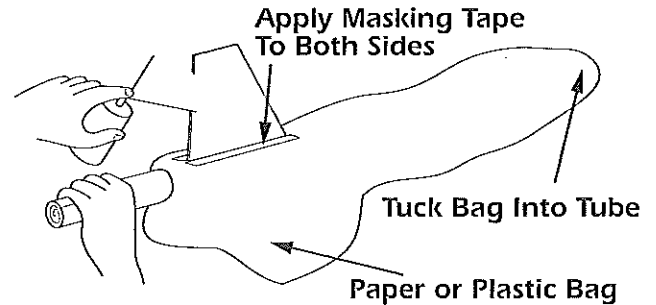

STEP 15

- A. If you don't intend to use the Payload Tube to carry payloads, we recommend you glue the Nose Cone and Transition to the Payload Tube.
 - B. If you don't glue these parts, make certain their fit is tight. This can be done by wrapping a piece of masking tape around the shoulder of the nose cone and the payload transition.
- NOTE:** Failure to glue or create a tight fit between these pieces may result in loss of nose cone, payload tube and payload.

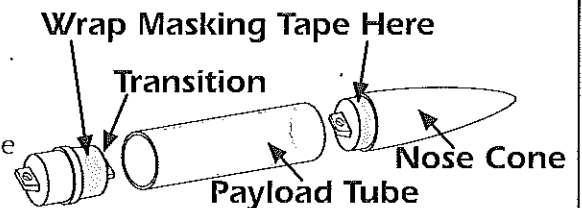

STEP 16

- A. Apply gripper tabs to parachute so holes in gripper tabs line up with holes in parachute. Firmly squeeze each gripper tab and parachute between your fingers.
- B. Assemble the parachute by passing the end of a shroud line through a hole in a gripper tab and tying 2 overhand knots. Tie each of the 6 ends of shroud line to the parachute through the gripper tab holes.
- C. Assembled parachute should appear as shown.

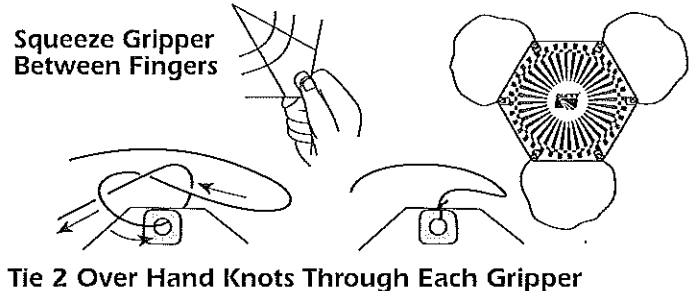

STEP 17

- A. Pass the shroud line loops through the eyelet on the transition. Pass parachute through loop ends and pull lines tightly against the eyelet.
- B. Use two overhand knots to tie the loose end of the shock cord onto the base of the nose cone.

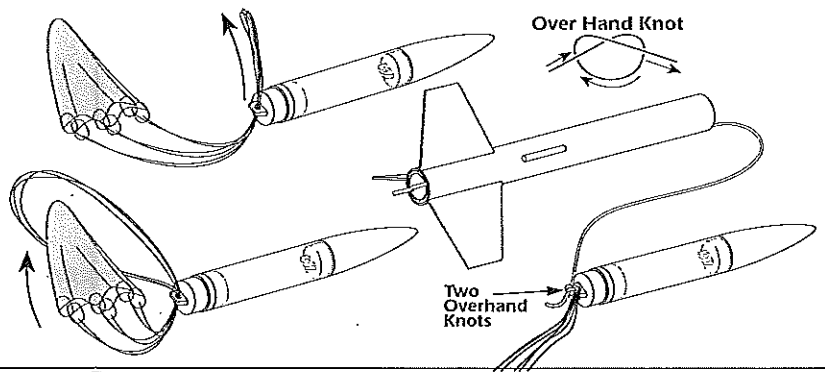

STEP 18

- When all paint is dry, apply the self-adhesive decals as shown.
- NOTE:** Use caution when removing the decal from the backing to prevent decal from curling over onto itself.

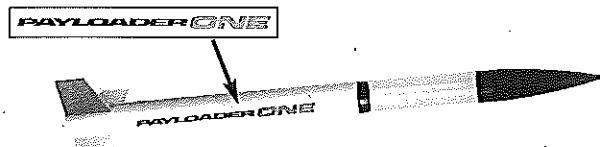

FLYING YOUR PAYLOADER ONE ROCKET

WHAT ELSE YOU WILL NEED:

To successfully fly your rocket you will need the following items:

- QUEST Launch Pad (No. 7610)
- QUEST Launch Controller (No. 7510)
- QUEST Parachute Recovery Wadding (No. 7021)
- QUEST Rocket Motors, Type A6-4, B6-4 or C6-5
- Use a A6-4 Motor for your first flights.

ESTIMATED ALTITUDES

The following is a guide to assist you in determining which motor to use based on the wind conditions and size of flying field available.

MOTOR	ESTIMATED ALTITUDE
A6-4	250 FEET
B6-4	450 FEET
C6-5	900 FEET

PREPPING YOUR ROCKET FOR FLIGHT

STEP 1

Pull the shock cord all the way out of the body tube. Crumple three sheets of recovery wadding and insert one by one into the body tube making sure that the Knot between the Kevlar and white elastic shock cord is on the nose cone side of the wadding. Wadding should fit loosely in the tube but tight enough to form a good seal against the wall of the body tube.

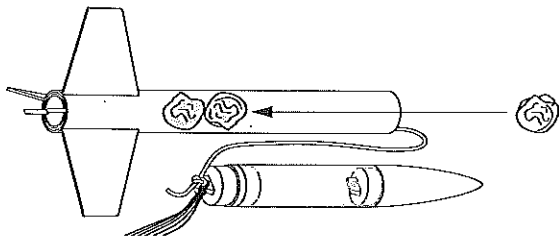

STEP 2

- Grab the parachute at its center and allow the rocket to hang from it. The weight of the rocket will pull the parachute into several triangular shapes.
- Gather the triangles together into one flat triangle.
- Fold the top of the parachute down over itself once.
- Now continue to roll the parachute over itself and roll the shroud lines around it.

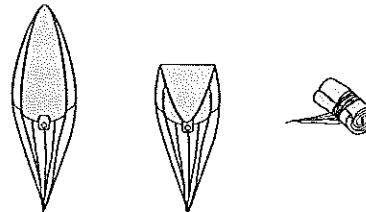

STEP 3

- Pack the parachute into the body tube. **THE PARACHUTE MUST SLIDE EASILY INTO THE TUBE.** If it is a tight fit, remove and re-fold the parachute.
TIP: LIGHTLY DUST YOUR PARACHUTE WITH TALCUM OR BABY POWDER TO KEEP IT FROM DEVELOPING A SET SHAPE. THIS TECHNIQUE IS ESPECIALLY EFFECTIVE IF THE WEATHER IS HOT AND HUMID OR VERY COLD.
- Push the shock cord into the tube and re-fit the nose cone onto the rocket. **BE CAREFUL NOT TO CATCH ANY OF THE SHOCK CORD BETWEEN THE SHOULDER OF THE NOSE CONE AND THE BODY TUBE.**

READ AND FOLLOW THE ENCLOSED LAUNCHING PROCEDURE SHEET

READ AND FOLLOW THE N.A.R. SAFETY CODE DURING ALL YOUR MODEL ROCKETRY ACTIVITIES.



Manufactured by:
QUEST AEROSPACE, INC.
P.O. Box 2409
Pagosa Springs, CO 81147
800-858-7302
www.questaerospace.com