

VIPER™

FLYING MODEL ROCKET ASSEMBLY INSTRUCTIONS



Skill Level One



Things You'll Need To Assemble this Kit:

Pencil:



White Glue:

Aliphatic Resin glues work best such as TITEBOND or ELMER'S CARPENTER'S WOOD GLUE - ELMER'S WHITE SCHOOL GLUE also works but dries slower.



BEFORE STARTING ASSEMBLY READ THROUGH THESE INSTRUCTIONS. IT IS BEST TO TEST FIT ALL PARTS BEFORE APPLYING ANY GLUE. READ AND FOLLOW THE N.A.R. MODEL ROCKET SAFETY CODE.

PARTS LIST

- | | | |
|-----------|-----------|----------------------------|
| A. | 49000 | Motor Clip |
| B. | 14000 | Blue Thrust Ring |
| C. | 10303S | Yellow Motor Mount Tube |
| D. | 14050 | Red Centering Rings (2) |
| E. | 21551 | Plastic Fin Unit |
| F. | 11305 | White Body Tube |
| G. | 20100 | Plastic Nose Cone |
| H. | 50053 | Elastic Shock Cord |
| I. | 50012 | Kevlar* Shock Cord |
| J. | 28107 | 14" Parachute |
| K. | 50100 | Pack of 3-26" Shroud Lines |
| L. | 50101 | 2 Strips of 3 GRIPPER Tabs |
| M. | 91517 | Self-adhesive Decal Sheet |
| N. | 96003R2JC | Instruction Sheet |
| O. | 90960R3JC | Launch Procedures Sheet |

* Kevlar is a registered trademark of Dupont

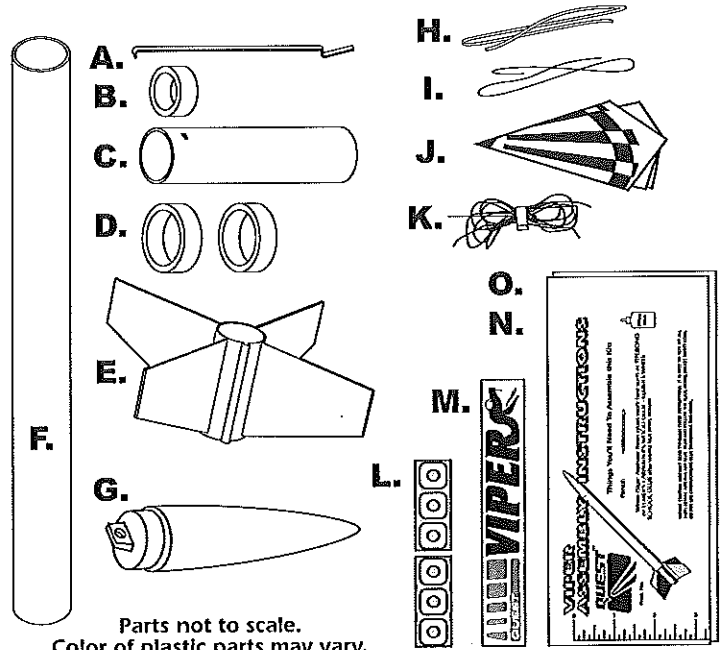

Parts not to scale.
Color of plastic parts may vary.

STEP 1

A. Place the Yellow Motor Mount Tube up against the ruler provided on the front page of these instructions. Make two pencil marks on the tube 1/2 inch from each end as shown.

B. Insert the Motor Clip into the slit in the Yellow Motor Mount Tube.

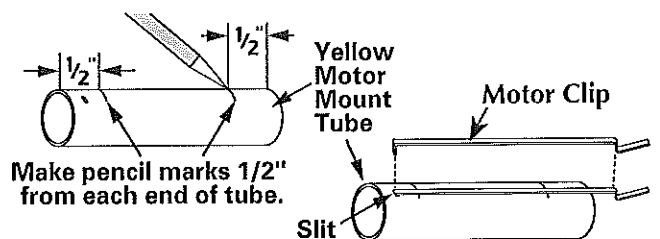

12311

STEP 2

A. Test fit one of the Red Centering Rings onto the Yellow Motor Mount Tube. If it does not slide on easily, stretch the Red Ring by sliding it over the Nose Cone and twisting it back and forth a few times. Slide the Red Ring onto the Yellow Tube just far enough to hold the Motor Clip in place.

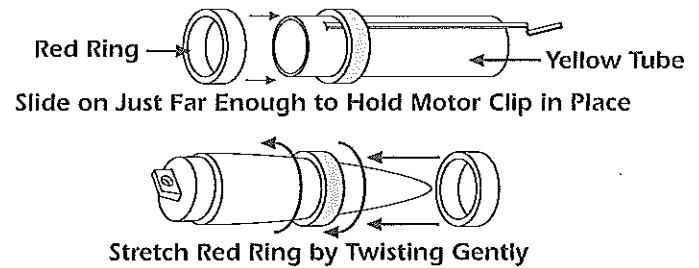

STEP 3

A. Apply a bead of white glue around the Yellow Motor Mount Tube on the inside of the pencil mark made in STEP 1, one half inch from the end as shown.

B. Slide the Red Ring into the bead of glue and up to the pencil mark. The edge of the Red Ring must be 1/2" from the end of the Yellow Motor Mount Tube. Wipe away any excess glue.

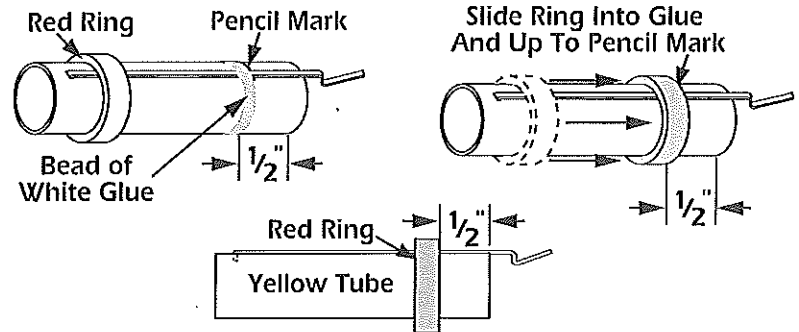

STEP 4

A. Hold the Yellow Kevlar Shock Cord and the White Elastic Shock Cord side by side. Pull one end of each cord so that they are even with each other. While holding the two cords together, tie a single parallel overhand knot approximately one inch from the even ends as shown.

B. Gently pull on both cords to set the knot and prevent it from slipping.

C. Apply a small amount of white glue on the ends of both cords to prevent them from fraying.

NOTE: THIS IS A VERY IMPORTANT STEP. IF YOU TIE A DIFFERENT TYPE OF KNOT THE SHOCK CORDS MAY SEPARATE DURING FLIGHT.

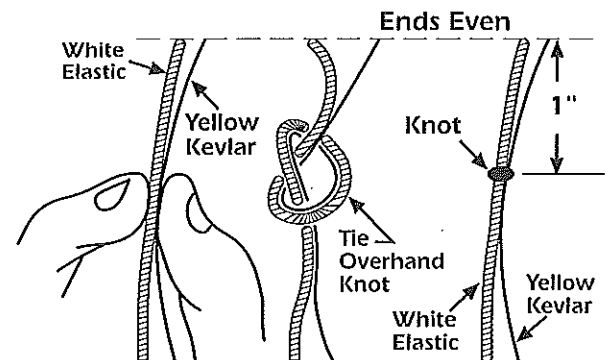

STEP 5

A. Tie two overhand knots 1 inch in from the end of the Yellow Kevlar Cord.

B. Pass the end of the Kevlar with the knot through the remaining Red Centering Ring.

C. Slide the Red Centering ring with the Kevlar under it onto the Yellow Motor Mount Tube.

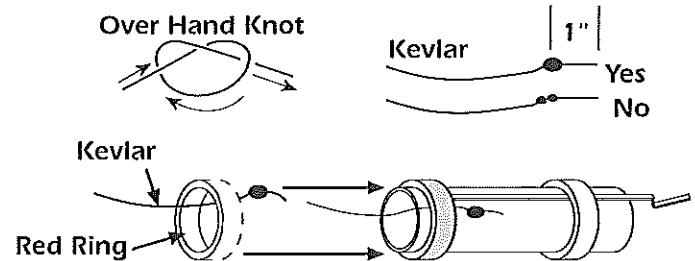

STEP 6

A. Apply a bead of white glue around the Yellow Motor Mount Tube 1/2 inch from the end as shown.

B. Slide the Red Ring into the bead of glue. Wipe away any excess glue.

C. Pull the Yellow Kevlar Shock Cord up tight against the Red Centering Ring.

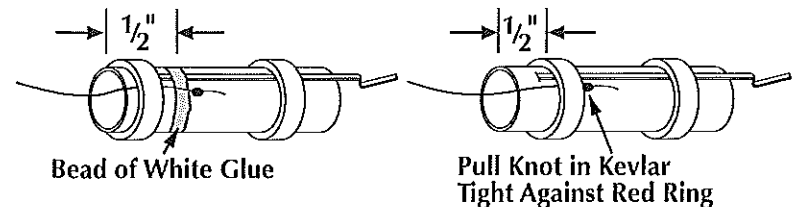

STEP 7

A. Apply white glue around inside edge of Yellow Motor Mount Tube as shown.

B. Insert the Blue Thrust Ring into the Yellow Motor Mount Tube so it is even with the end of the Yellow Motor Mount Tube.

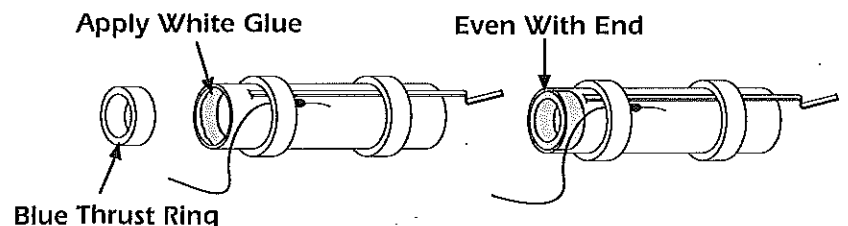

STEP 8

- A.** Stretch one end of the Body Tube slightly by inserting the nose cone into the tube and gently twisting it back and forth a few times.
- B.** Hold the Body tube with the stretched end facing up and "feed" the shock cord into the tube until the cord comes out the other end.
- C.** Grab the end of the shock cord and pull it all the way through the tube until the Motor Mount Assembly that is attached to the other end pulls up against the tube.

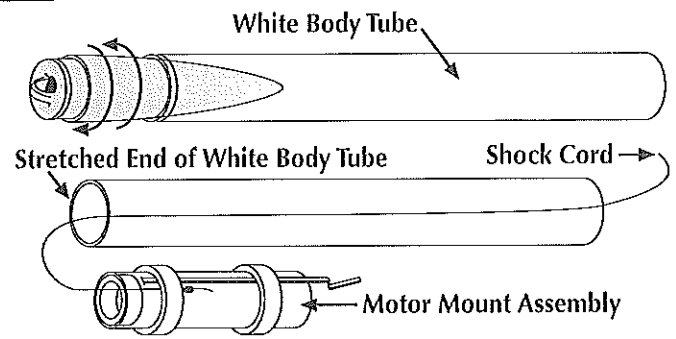

STEP 9

- A.** Hold the Motor Mount Assembly and the Body Tube in one hand.
- B.** Apply White Glue around the inside of the Body Tube.
- C.** Immediately insert the Motor Mount Assembly and PUSH IT INTO THE BODY TUBE WITH ONE FAST & SMOOTH MOTION until the Yellow Motor Mount Tube is even with the end of the body tube.

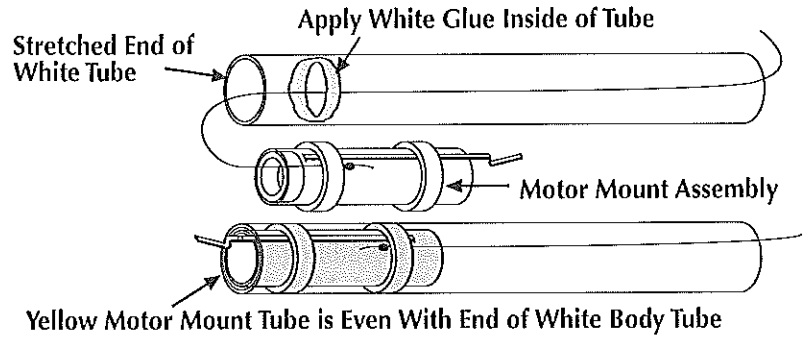

STEP 10

- A.** Apply a small bead of white glue around the outside of the body tube as shown.
- B.** Slide the one-piece molded plastic Fin Unit onto the body tube with a twist as you push.
- B.** Slide the Fin Unit onto the body tube until it is flush with the end of the White Body Tube.

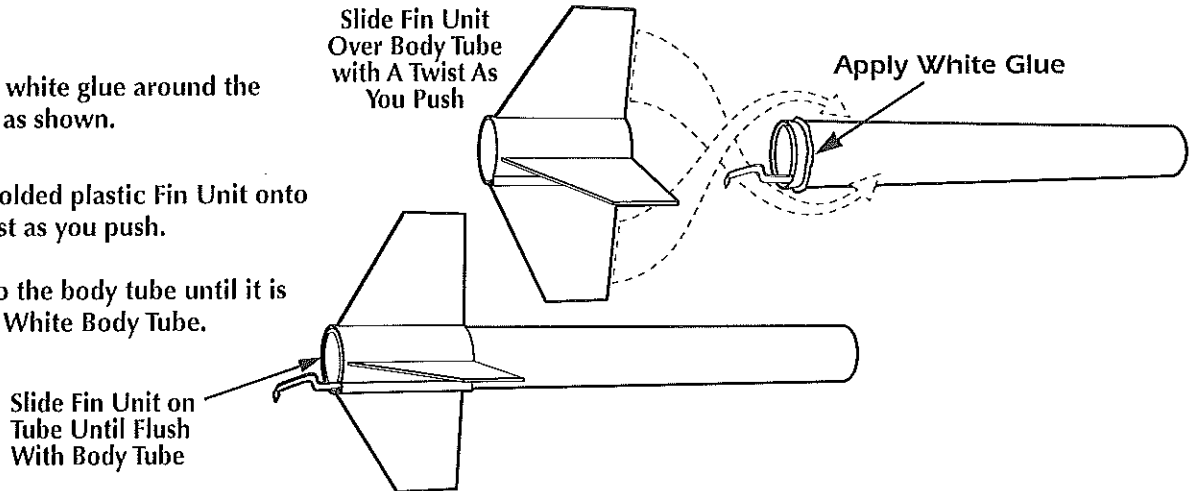

STEP 11

- A.** Apply gripper tabs to parachute so holes in gripper tabs line up with holes in parachute. Firmly squeeze each gripper tab and parachute between your fingers.
- B.** Assemble the parachute by passing the end of a shroud line through a hole in a gripper tab and tying 2 overhand knots. Tie each of the 6 ends of shroud line to the parachute through the gripper tab holes.
- C.** Assembled parachute should appear as shown.

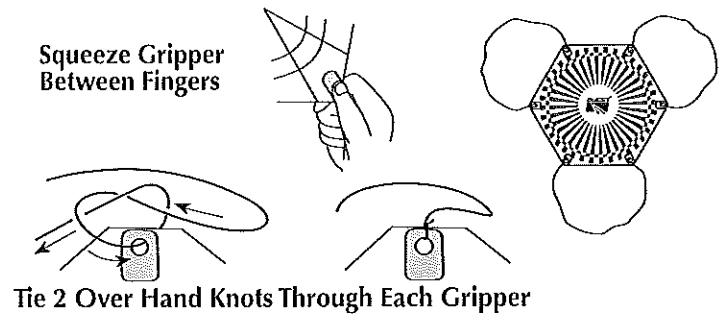

STEP 12

- A.** Use two overhand knots to tie the loose end of the shock cord onto the base of the nose cone.
- B.** Pass the shroud line loops through the eyelet on the nose cone. Pass parachute through loop ends and pull lines tightly against the eyelet.
- C.** If the nose cone fits too loose, wrap a short piece of tape around the shoulder of the nose cone until you get a snug but not tight fit.

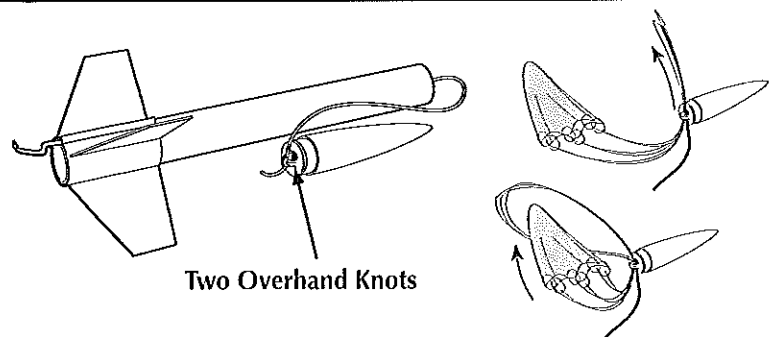

STEP 13

A. Remove decal slowly from the backing to prevent decal from curling over onto itself. Once decal is removed from backing, hold decal at each end while placing it into position.

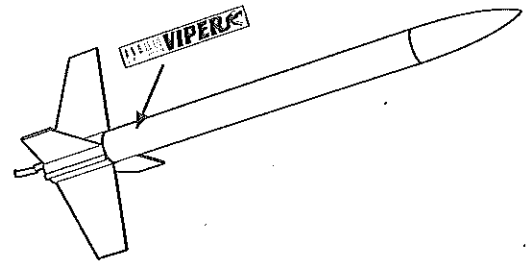

FLYING YOUR VIPER ROCKET

WHAT ELSE YOU WILL NEED

To successfully fly your rocket you will need the following items:

- QUEST Lift Off Launch Pad (No. 7610)
- QUEST Futuristic Launch Controller (No. 7510)
- QUEST Parachute Recovery Wadding (No. 7021)
- QUEST Rocket Motors, Type A6-4, A8-3, B6-4, C6-3 or C6-5
- Use a A6-4 Motor for your first flight.

ESTIMATED ALTITUDES

The following is a guide to assist you in determining which motor to use based on the wind conditions and size of flying field available.

MOTOR	ESTIMATED ALTITUDE
A6-4	250 FEET
A8-3	300 FEET
B6-4	450 FEET
C6-3	850 FEET
C6-5	1000 FEET

PREPPING YOUR ROCKET FOR FLIGHT

STEP 1

Pull the shock cord all the way out of the body tube. Crumple three sheets of recovery wadding and insert one by one into the body tube making sure that the knot between the Kevlar and white elastic shock cord is on the nose cone side of the wadding. Wadding should fit loosely in the tube but tight enough to form a good seal against the wall of the body tube.

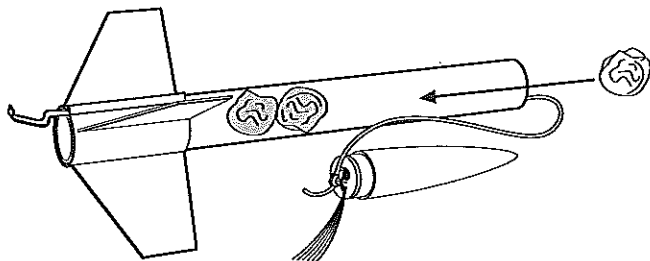

STEP 2

- Grab the parachute at its center and allow the rocket to hang from it. The weight of the rocket will pull the parachute into several triangular shapes.
- Gather the triangles together into one flat triangle.
- Fold the top of the parachute down over itself once.
- Now continue to roll the parachute over itself and roll the shroud lines around it.

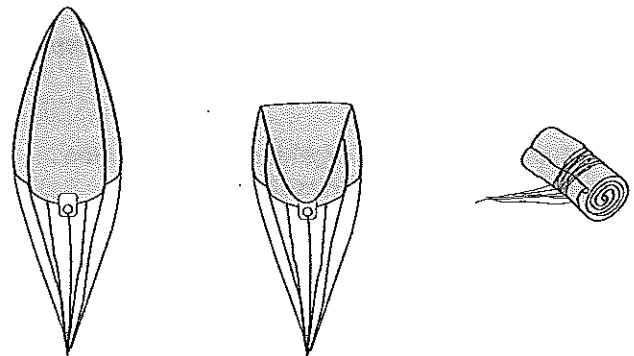

STEP 3

- Pack the parachute into the body tube. THE PARACHUTE MUST FIT LOOSELY INTO THE TUBE. If it is a tight fit, remove and re-fold the parachute.
TIP: Lightly dust your parachute with talcum powder or baby powder to keep it from developing a set shape. This technique is especially effective if the weather is hot and humid or very cold.
- Push the shock cord into the tube and re-fit the nose cone onto the rocket. BE CAREFUL NOT TO CATCH ANY OF THE SHOCK CORD BETWEEN THE SHOULDER OF THE NOSE CONE AND THE BODY TUBE

READ AND FOLLOW THE ENCLOSED LAUNCH PROCEDURE SHEET

READ AND FOLLOW THE N. A. R. SAFETY CODE DURING ALL YOUR MODEL ROCKETRY ACTIVITIES.

Visit our website at:

questaerospace.com

QUEST 
Shaping the future of model rocketry™

QUEST AEROSPACE, INC.
PO Box 2409
Pagosa Springs, CO 81147
800-858-7302