

NOVIA™

ASSEMBLY INSTRUCTIONS

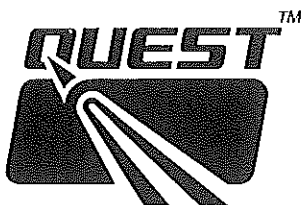

Skill Level One

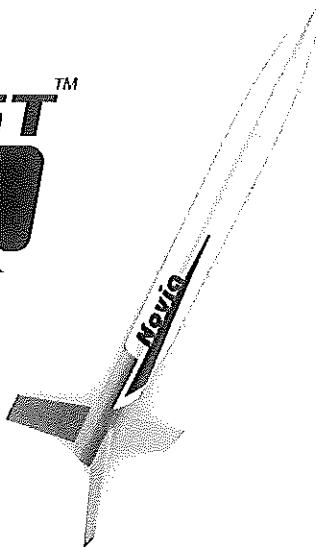

Things You'll Need To Assemble this Kit:
Hobby Knife, Pencil and Paint Brush



Sandpaper (220 or 320 Grit) & Sanding Sealer

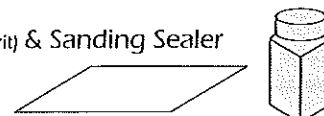

White Glue

Aliphatic Resin glues work best such as TITEBOND or ELMER'S CARPENTER'S WOOD GLUE - ELMER'S WHITE SCHOOL GLUE also works but dries slower.

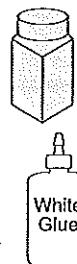

Tape & Paint

Scotch Magic Tape or Paper Masking Tape and Spray Paint

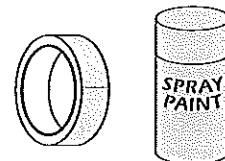

BEFORE STARTING ASSEMBLY READ THROUGH THESE INSTRUCTIONS. IT IS BEST TO TEST FIT ALL PARTS BEFORE APPLYING ANY GLUE. READ AND FOLLOW THE NAR MODEL ROCKET SAFETY CODE.

PARTS LIST

- A. 49000 Motor Clip
- B. 10303S Yellow Motor Mount Tube
- C. 14000 Blue Thrust Ring
- D. 11201 Body Tube
- E. 20075 Nose Cone
- F. 33006 Die-Cut Balsa Fin Set
- G. 10000 1 inch Launch Lug
- H. 50051 18 inch Kevlar* Shock Cord
- I. 50014 21 inch Elastic Shock Cord
- J. 28150 24 inch Plastic Streamer
- K. 28004 Single Gripper Tab
- L. 96000R Instruction Sheet
- M. 90960R Launch Procedures Sheet
- N. 91500 Decal Sheet

* Kevlar is a registered trademark of Dupont

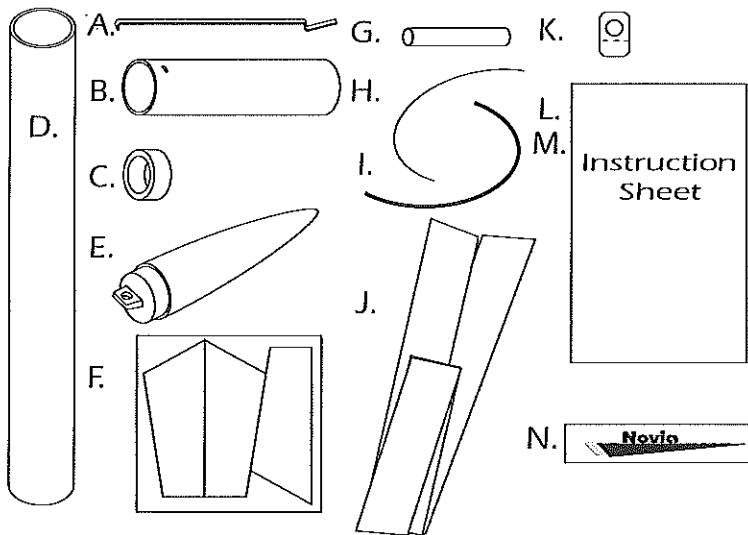

STEP 1

A. Hold the Yellow Kevlar Shock Cord and the White Elastic Shock Cord side by side. Pull one end of each cord so that they are even with each other. While holding the two cords together, tie a single parallel overhand knot approximately one inch in from the even ends as shown.

B. Gently pull on both cords to set the knot and prevent it from slipping.

C. Apply a small amount of white glue on the ends of both cords to prevent them from fraying.

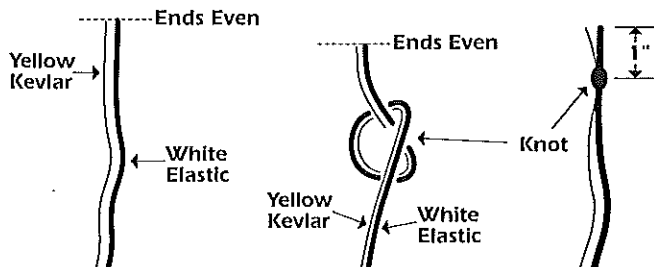

NOTE: THIS IS A VERY IMPORTANT STEP. IF YOU TIE A DIFFERENT TYPE OF KNOT THE SHOCK CORDS MAY SEPARATE DURING FLIGHT.

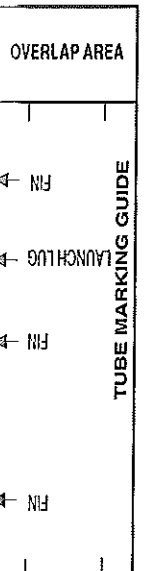
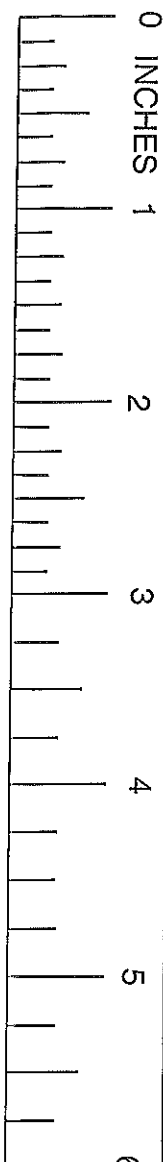

STEP 2

A. Use a sharp hobby knife to cut a shallow "V" slot in the Blue Thrust Ring as shown. Test fit the Blue Thrust Ring into one end of the Yellow Motor Mount Tube. If the fit is tight, sand the outside of the Blue Thrust Ring until you get a looser fit.

B. Tie the Yellow Kevlar Shock Cord onto the Blue Thrust Ring using two overhand knots as shown. Be sure the shock cord lays in the "V" you made in the Blue Thrust Ring.

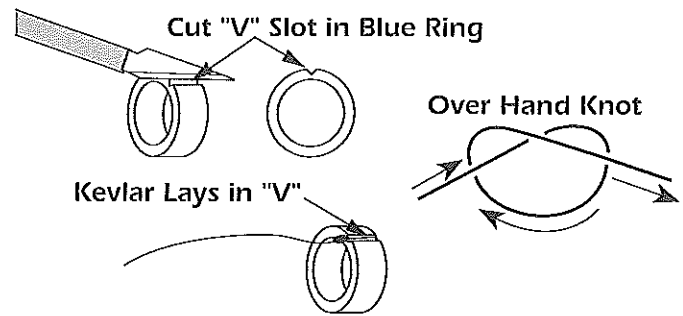

STEP 3

A. Apply white glue around the inside edge of the Yellow Motor Mount Tube between the slit and end of the tube as shown.

B. Insert the Blue Thrust Ring into the Yellow Motor Mount Tube with the Yellow Kevlar and knot facing as shown until it is even with the end of the Yellow Motor Mount Tube.

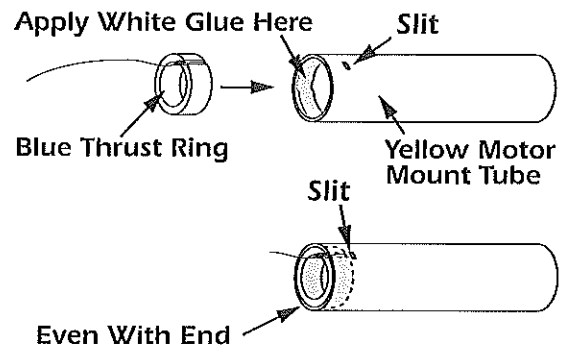

STEP 4

A. Using the ruler on the front of the instruction sheet, make a pencil mark 1/4 inch from the end of the Yellow Motor Mount Tube as shown.

B. "Feed" the shock cord back through the Yellow Motor Mount as shown.

C. Make a slight bend in the motor clip as shown. Insert the clip into the slit in the Yellow Motor Mount Tube.

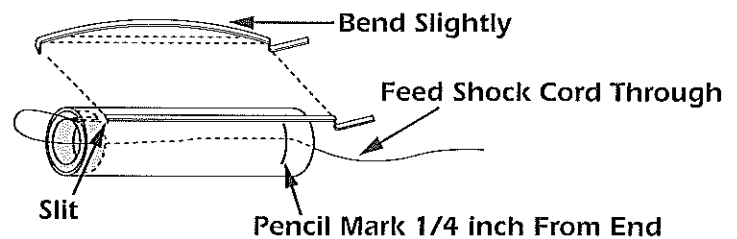

STEP 5

A. Apply white glue around the inside of one end of the White Body Tube.

B. Orient the Yellow Motor Mount tube as shown and immediately insert it into the White Body Tube and PUSH INTO THE BODY TUBE WITH ONE FAST & SMOOTH MOTION up to the 1/4 inch pencil mark on the Yellow Motor Mount Tube as shown.

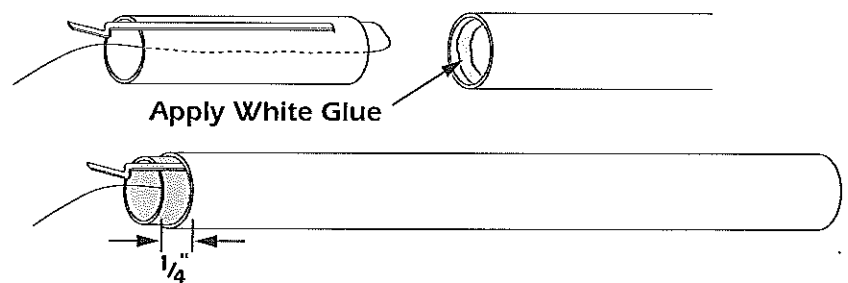

STEP 6

A. Cut out the tube marking guide from the front page of the instruction sheet

B. Wrap the tube marking guide around the body tube. Align the arrow that is marked "Launch Lug" with the motor clip. Mark the body tube at each of the arrows with a pencil.

C. Use a door frame as a guide and extend each of the pencil marks 3 inches up from the rear of the body tube.

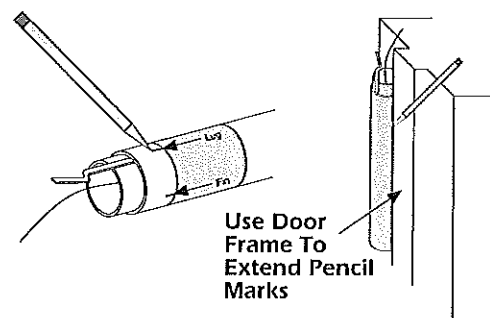

STEP 7

- Carefully remove each of the three die-cut balsa fins from the sheet with a sharp hobby knife.
- Stack the fins together and sand all edges smooth.
- Rub a small line of white glue into the root edge of each fin and set aside to dry.

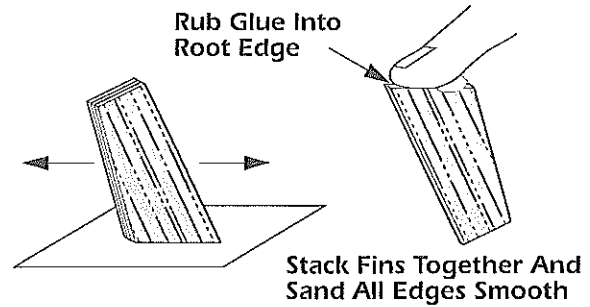

STEP 8

- Apply a small line of white glue along the root edge of a fin and position it along one of the fin lines on the body tube. Adjust the fin so that it projects straight away from the body tube as shown. Allow the glue to set for a few minutes before attempting to glue on the remaining fins. Repeat this step for the remaining two fins.
- After the glue is completely dry apply a small bead of white glue to both sides of a fin-body tube joint. Smooth out the glue with your finger. Wipe excess glue off your finger onto a tissue or paper towel.
- Repeat the above step for the remaining fin-body tube joints. Set aside to dry.

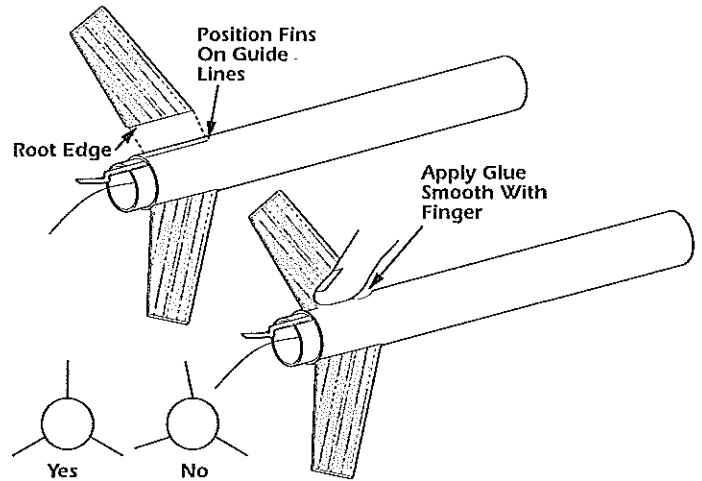

STEP 9

- Make a pencil mark on the launch lug line 3 inches from the rear of the rocket as shown.
- Apply white glue to the launch lug and place along the pencil line with one end even with the mark 3 inches from the rear of the rocket as shown.

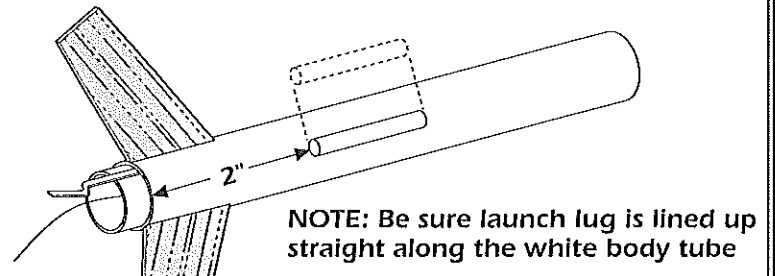

STEP 10

- After all the glue is completely dry apply a coat of sanding sealer to each fin. When sealer is dry, lightly sand each fin.
- Repeat the sealing and sanding process until the surface of each fin is smooth.

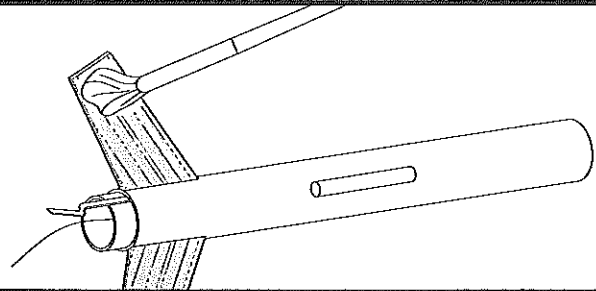

STEP 11

- Feed the shock cord back through the body tube until you are able to grab it from the front end and pull it all the way out the front.
- Peel the backing off the gripper tab and attach it to one end of the plastic streamer.
- Feed the loose end of the shock cord through the hole in the gripper tab.
- Use two overhand knots to tie the loose end of the shock cord onto the nose cone.

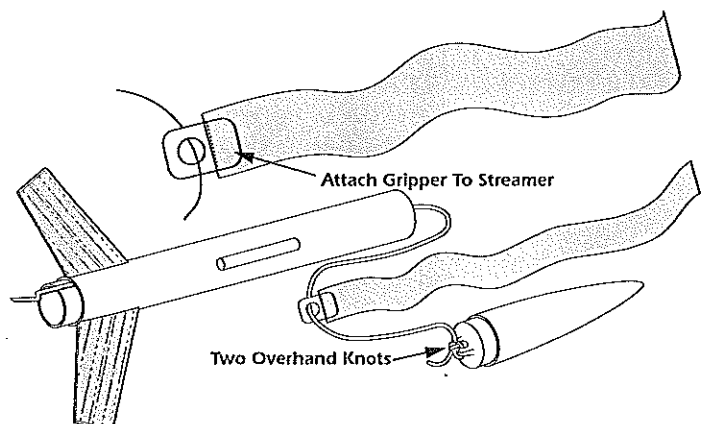

STEP 12

A. Paint the entire rocket with gloss white spray enamel. Follow the instructions on the spray can for best results.

B. After yellow paint is completely dry, apply masking tape around the body tube 3 inches from the rear of the tube. Protect the rest of the rocket with a plastic or paper bag. Spray paint the entire rear section of the rocket gray black. Carefully remove the masking tape after paint is dry.

NOTE: For the best surface finish on your rocket, spray entire model with primer and sand before painting.

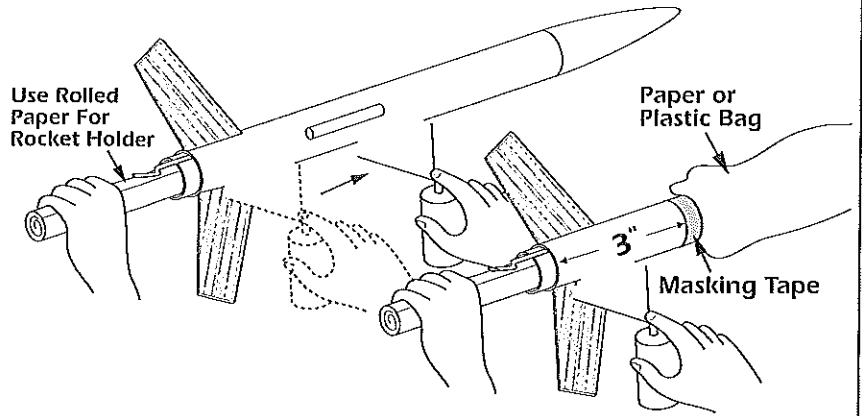

STEP 13

A. Apply the self-adhesive decal to your rocket as shown here.

NOTE: Use caution when removing the decal from the backing to prevent decal from curling over onto itself.

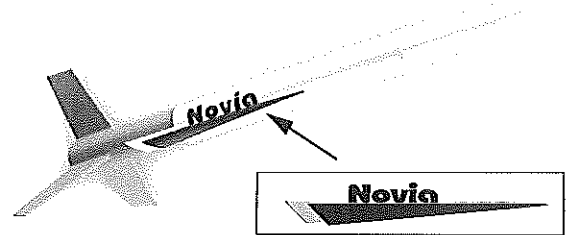

FLYING YOUR NOVIA ROCKET

WHAT ELSE YOU WILL NEED:

To successfully fly your rocket you will need the following items:

- QUEST Launch Pad (No. 7610)
- QUEST Launch Controller (No. 7510)
- QUEST Parachute Recovery Wadding (No. 7020)
- QUEST Rocket Motors, Type A6-4, A8-3, B6-4 or C6-5
- Use a A6-4 Motor for your first flights.

ESTIMATED ALTITUDES

The following is a guide to assist you in determining which motor to use based on the wind conditions and size of flying field available.

MOTOR	ESTIMATED ALTITUDE
A6-4	450 FEET
B6-4	800 FEET
C6-5	1400 FEET

PREPPING YOUR ROCKET FOR FLIGHT

STEP 1

Pull the shock cord all the way out of the body tube. Crumple three sheets of recovery wadding and insert one by one into the body tube making sure that the Knot between the Kevlar and white elastic shock cord is on the nose cone side of the wadding. Wadding should fit loosely in the tube but tight enough to form a good seal against the wall of the body tube.

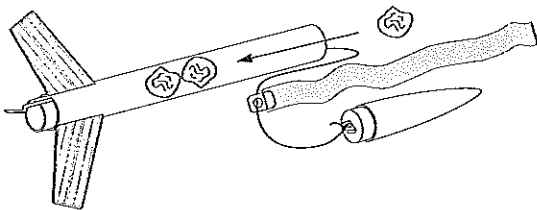

STEP 2

A. Grab the plastic streamer at its center and fold it in half. Continue to fold the streamer in half until small enough to roll tightly.

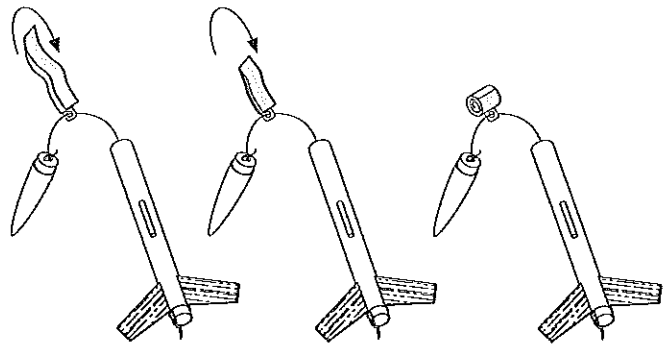

STEP 3

- A. Pack the streamer into the body tube. **THE STREAMER MUST SLIDE EASILY INTO THE TUBE.** If it is a tight fit, remove and re-fold the streamer.
- B. Push the shock cord into the tube and re-fit the nose cone onto the rocket. **BE CAREFUL NOT TO CATCH ANY OF THE SHOCK CORD BETWEEN THE SHOULDER OF THE NOSE CONE AND THE BODY TUBE.**

READ AND FOLLOW THE ENCLOSED LAUNCHING PROCEDURE SHEET

READ AND FOLLOW THE N.A.R. SAFETY CODE DURING ALL YOUR MODEL ROCKETRY ACTIVITIES.

